

KINAX 3W2

Transmitter for Angular Position

Application

The **KINAX 3W2** (Figs. 1 to 3) converts the angular position of a shaft into a **load independent** direct current signal, proportional to the angular position. The unit is **contact free** and has **minimal mechanical abrasion** on the input shaft. It is a technically purposeful complement to the angle transmitter program. This compacter version is made possible by incorporating newly developed, highly integrated CMOS circuitry.

Features / Benefits

- Measuring input: Angular position

Measured variable	Measuring range limits
Angular position	0 ... 5° to 0 ... 270°

- Capacitive scanning system / Non mechanical abrasion, low annual maintenance
- Low influence from bearing play, < 0.1%
- Accuracy $\leq 0.5\%$ for ranges $\leq 150^\circ$
- Torque < 0.001 Ncm
- Drive shaft fully rotatable without stops
- For building into other equipment and as an OEM product / Very compact made only 48 mm in diameter
- Marine version also available as per Lloyd's Register of Shipping
- Available in type of protection "Intrinsic safety" EEx ia IIC T6 / Can be mounted within the hazardous area (see "Table 3: Data on explosion protection)

Layout and mode of operation

The transmitter consists of 2 main parts: the differential screen capacitor D and the electronic circuitry E (see Fig. 4).

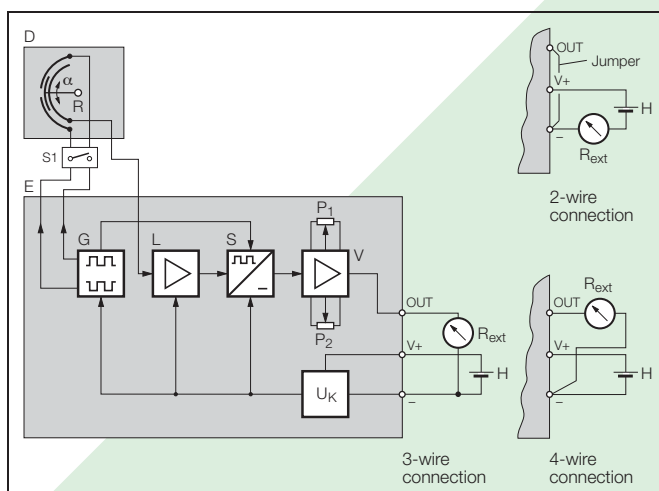

Fig. 4. Block diagram



Fig. 1. KINAX 3W2 with shaft dia. 2 mm.



Fig. 2. KINAX 3W2 with shaft dia. 6 mm.

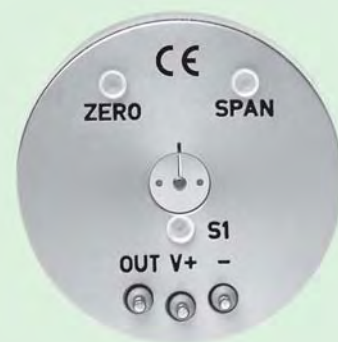

Fig. 3. Rear view with electrical connections and potentiometers for zero and FS.

S1 = Change-over switch sense of rotation for $\alpha > 150^\circ$

KINAX 3W2

Transmitter for Angular Position

The angular deflection α of the device to be measured is transferred to the rotor R of the differential screen capacitor with the aid of a mechanical coupling. It is then converted into a change of capacitance proportional to the angle.

The generator G produces 2 square voltages of 8 kHz shifted in phase by 180 degrees. These voltages are applied to the differential screen capacitor.

Any change in the rotor position results in a change of current at the charge amplifier input L. This current is amplified, rectified with the synchronous rectifier S, and passes to the output amplifier V, which converts it into a load-independent DC current.

The constant voltage source U_K supplies the circuit with a stable voltage which is independent of power supply fluctuations. Zero setting and end value can be adjusted with the potentiometers P_1 and P_2 .

Standard ranges:	0...1 mA, 3- or 4-wire connection
	0...5 mA, 3- or 4-wire connection
	0...10 mA, 3- or 4-wire connection
	4...20 mA, 3- or 4-wire connection
	4...20 mA, 2-wire connection or 0...20 mA, 3- or 4-wire connection adjustable with potentiometer
Non-standard ranges:	0...> 1.00 to 0...< 20 mA 3- or 4-wire connection

External resistance (load): $R_{\text{ext max.}} [\text{k}\Omega] = \frac{H [\text{V}] - 12 \text{ V}}{I_A [\text{mA}]}$

H = DC power supply
 I_A = Output signal end value

Residual ripple in output current: < 0.3% p.p.

Response time: < 5 ms

Technical data

General

Measured quantity:	Angle of rotation α \curvearrowright °
Measuring principle:	Capacitive method Differential screen capacitor with contact-free, non-wearing positional pick-up. Drive shaft fully rotatable without stops

Measuring input \rightarrow

Standard measuring ranges of rotation angle α : 0...10°, 0...30°, 0...60°, 0...90°, 0...180°, 0...270°

Drive shaft diameters: 2 or 6 mm resp. 1/4"

Frictional torque: < 0.001 Ncm with shaft dia. 2 mm
< 0.03 Ncm with shaft dia. 6 mm resp. 1/4"

Sense of rotation as seen from the shaft side: $\curvearrowright \leq 150^\circ$ possible in both senses of rotation (specify the required sense of rotation)
 $\curvearrowright > 150^\circ$ to $\leq 270^\circ$, sense of rotation switchable with switch S1 (initial and end value must be readjusted)

Measuring output \rightarrow

Output variable I_A :	Load-independent DC current, proportional to the input angle
Zero point correction:	Approx. $\pm 5\%$
Span adjustment:	Approx. + 5 / - 30%, see Feature 6
Current limitation:	I_A max. 40 mA

Accuracy

Reference value:	Measuring range
Basic accuracy:	Limit of error $\leq \pm 0.5\%$ for ranges 0 ... $\leq 150^\circ$ Limit of error $\leq 1.5\%$ for ranges from 0... > 150° to 0 ... 270°
Reproducibility:	< 0,2%

Reference conditions

Ambient temperature	23 °C \pm 2 K
Power supply	18 V DC
External resistance	$R_{\text{ext}} = 0 \Omega$

Influence effects (maxima) (included in basic error)

Linearity error:	$\pm 0.4\%$ for ranges 0... $\leq 150^\circ$ $\pm 1.4\%$ for ranges from 0...> 150° to 0...270°
------------------	--

Dependence on external resistance $\Delta R_{\text{ext max.}}$ $\pm 0.1\%$

Power supply influence $\pm 0.1\%$

Additional errors (maxima)

Temperature influence (- 25...+ 70 °C)	$\pm 0.2\%$ / 10 K
Bearing play influence	$\pm 0.1\%$

KINAX 3W2

Transmitter for Angular Position

Power supply H → ○

DC voltage: Version non intrinsically safe
12 ... 33 V
Version intrinsically safe 12...**30 V**
max. residual ripple 10% p.p.
(12 V must not be understepped)
Protected against wrong polarity

Installation data

Dimensions: See section
"Dimensional drawings"

Housing: Chromated aluminium

Mounting position: Any

Electrical connections: Soldering terminals
Protection class IP 00 acc. to
IEC 529

Permissible vibrations: 5 g every 2 h in 3 directions
f ≤ 200 Hz

Shock: 3 x 50 g
10 shocks each in 3 directions

Admissible static loading of shaft:	Drive shafts dia.	2 mm	6 mm
	Sense		resp. 1/4"
	radial max.	16 N	83 N
	axial max.	25 N	130 N

Weight: Approx. 100 g

Fixation: 3 cheesehead screws M3 or with 3
clamps

Regulations

Electromagnetic compatibility: The standards DIN EN 50 081-2 and
DIN EN 50 082-2 are observed

Intrinsically safe: Acc. to EN 50 020: 1994

Impulse voltage withstand: 1 kV, 1,2/50 μs, 0.5 Ws
IEC 255-4, Cl. II

Housing protection: IP 50 acc. to IEC 529

Test voltage: All connections against housing
500 Veff., 50 Hz, 1 min.

Admissible common-mode
voltage: 100 V, 50 Hz

Environmental conditions

Climatic rating: Standard version
Temperature -25 to + 70 °C
Annual mean
relative humidity ≤ 90%
or
Version with improved climatic ra-
ting
Temperature -40 to + 70 °C
Annual mean
relative humidity ≤ 95%
Ex-version
Temperature
- 40 to + 60 °C at T6
resp. - 40 to + 75 °C at T5

Transportation and
storage temperature: -40 to 80 °C

Table 1: Stock versions

The following transmitter versions are available ex stock. It is only necessary to quote the Order No.:

Order Code *)	Version	Sense of rotation	Measuring range (angle)	Output signal/ power supply 12...33 V DC	Order No.
708 - 112D	Standard (non intrinsically safe) with shaft dia. 2 mm, length 6 mm	Clockwise	0... 30°	4...20 mA 2-wire connection or 0...20 mA 3- or 4-wire connection (adjustable with potentiometer)	989 759
708 - 113D			0... 60°		993 213
708 - 114D			0... 90°		993 221
708 - 116D			0...270°		993 239

*) See section "Specifications and ordering information"

Instruments ex stock are factory set to output 4...20 mA for use in 2-wire connection.

When changing from 2- to 3- or 4-wire connection the initial and end values must be readjusted with P1 and P2 respectively.

The complete Order Code 708 - and/or a description according to the section "Specifications and ordering information" should be stated for other versions.

KINAX 3W2

Transmitter for Angular Position

Table 2: Specification and ordering information

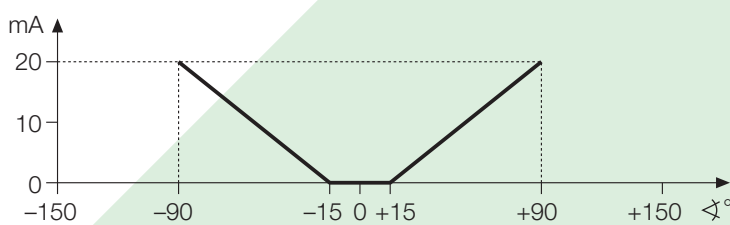
Features, Selection	*Blocking code	no-go with blocking code	Article No./ Feature
KINAX 3W2 Order Code 708 - xxxx xxxx x			708 -
Features, Selection			
1. Version of the transmitter (with standard shaft dia. 2 mm, at front only , length 6 mm*)			
Standard, measuring output non intrinsically safe	A		1
EEx ia IIC T6, measuring output intrinsically safe	B		2
Customized, measuring output intrinsically safe (Japan, on request)	B		5
Ex ia IIC T6, measuring output intrinsically safe, FTZU (Czech republic)	B		6
Other versions on request	B		9
2. Sense of rotation			
Calibrated for sense of rotation clockwise	D		1
Calibrated for sense of rotation counterclockwise	D		2
For "V" characteristic	E		3
Both senses of rotation, calibrated and marked (for measuring ranges $\leq 90^\circ$ only)	M		4
Lines 1 and 2: Angle $\leq 150^\circ$ usable in both senses of rotation. Angle $> 150^\circ$ to $\leq 270^\circ$ switchable to the other direction.			
3. Measuring range (measuring input) \rightarrow			
0 ... 10 \curvearrowright°		E	1
0 ... 30 \curvearrowright°		E	2
0 ... 60 \curvearrowright°		E	3
0 ... 90 \curvearrowright°		E	4
0 ... 180 \curvearrowright°		EM	5
0 ... 270 \curvearrowright°		EM	6
Non-standard 0 ... ≥ 5 to 0 ... < 270 $[\curvearrowright^\circ]$ 		E	9
With both senses of rotation calibrated, non-standard range, 0 to ≥ 5 till 0 to $< 90^\circ$			
"V" characteristic $[\pm \curvearrowright^\circ]$ 		DM	A
Specify start M_A and end M_E of measuring range! Observe the limits for ($M_A [\pm \curvearrowright^\circ] \geq 10$ and $M_E [\pm \curvearrowright^\circ] \leq 150$) and give both angles separated by an oblique stroke, e.g. $[\pm \curvearrowright^\circ] 15/90!$			
 <p>Example of a "V" characteristic for the measuring range $[\pm \curvearrowright^\circ] 15/90$ and an output range of 0...20 mA</p>			

* Possible deviations see selection 7!

KINAX 3W2

Transmitter for Angular Position

Features, Selection	*Blocking code	no-go with blocking code	Article No./ Feature
KINAX 3W2 Order Code 708 - xxxx xxxx x			708 –
Features, Selection			
4. Output signal (measuring output) $\ominus \rightarrow$ / Connecting version Power supply (12 ... 33 V DC resp. 12 ... 30 V DC with Ex version)			
0 ... 1 mA / 3- or 4-wire connection			A
0 ... 5 mA / 3- or 4-wire connection			B
0 ... 10 mA / 3- or 4-wire connection			C
4 ... 20 mA / 2-wire connection or 0 ... 20 mA / 3- or 4-wire connection (adjustable with potentiometer)			D
4 ... 20 mA / 3- or 4-wire connection			E
Non-standard, 3- or 4-wire connection			
0 ... > 1.00 to 0 ... < 20 [mA] 			Z
R _{ext} max. see section "Technical data", output signal			
5. Special features			
Without (order code complete)	Y		0
With special feature The features to be omitted must be marked hereafter with / (slant line) in the order code until reaching the required feature!			1
6. Adjustability (span adjustment)			
Increased adjustability + 5% / – 60% Restriction: for angle $\geq 60^\circ$, additional error 0.2%		Y	A
7. Drive shaft special			
Dia. 2 mm at front, length 12 mm, dia. 2 mm rear, length 6 mm		Y	C
Dia. 6 mm at front, length 12 mm		Y	D
Dia. 6 mm at front, length 12 mm, dia. 2 mm rear, length 6 mm		Y	E
Dia. 1/4 " at front, length 12 mm		Y	F
Dia. 1/4 " at front, length 12 mm, dia. 2 mm rear, length 6 mm		Y	G
8. Improved climatic rating			
Temperature – 40 to + 70 °C, annual mean relative humidity $\leq 95\%$ instead of $\leq 90\%$ for the standard version		BY	H
With Ex version Temperature – 40 to + 60 °C at T6 resp. – 40 to + 75 °C at T5, annual mean relative humidity $\leq 95\%$		AY	J
9. Marine version			
Version GL ("Germanischer Lloyd")		Y	L

* Lines with letter(s) under «no-go» cannot be combined with preceding lines having the same letter under «Blocking code».

Table 3: Data on explosion protection

Order Code	Type of protection "Intrinsically safe"		Certificates	Mounting location of device
	Instrument	Marking		
708 - 2 ...	EEx ia IIC T6	Measuring output	Type Examination Certificate PTB 97 ATEX 2271	Within the hazardous area
708 - 5 ...	(Customized) on request	U _i = 30 V I _i = 160 mA P _i = 1 W C _i = 10 nF	Japan	
708 - 6 ...	Ex ia IIC T6	L _i = 0	Czech republic FTZU 98 Ex 0280	

KINAX 3W2

Transmitter for Angular Position

Electrical connections

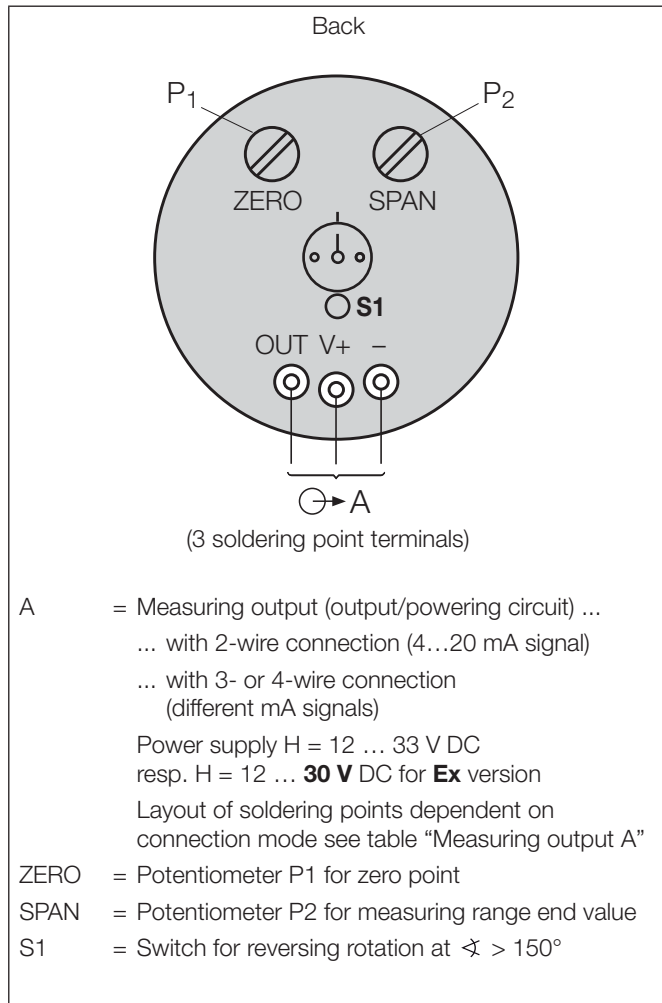

Measuring output A	
Connection mode	Terminal allocation
2-wire connection (4 ... 20 mA)	
3-wire connection	
4-wire connection	

R_{ext} = External resistance
 H = Power supply

P1, Potentiometer for zero point
 P2, Potentiometer for measuring range end value

When changing from 2- to 3- or 4-wire connection the initial and end value must be readjusted with P1 and P2 respectively.

Dimensional drawings

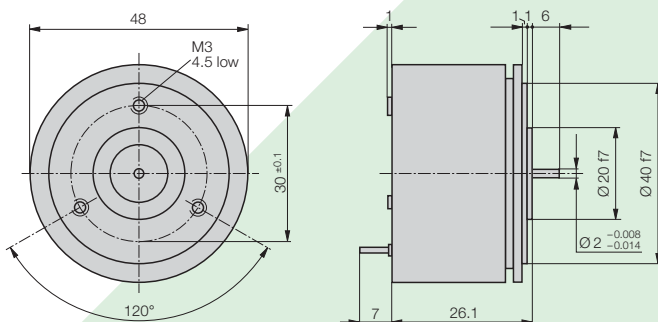

Fig. 5. KINAX 3W2 with shaft dia. 2 mm, length 6 mm, standard version.

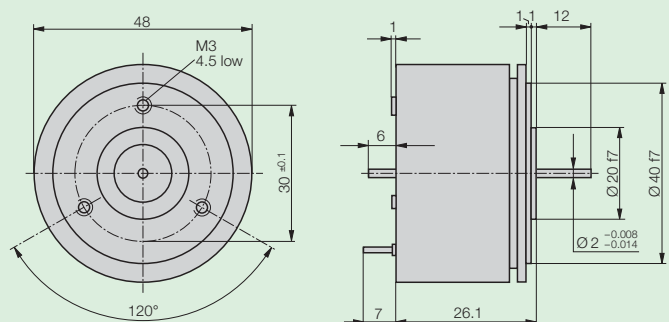

Fig. 6. KINAX 3W2 with shaft dia. 2 mm at front, length 12 mm, dia. 2 mm rear, length 6 mm.

KINAX 3W2 Transmitter for Angular Position

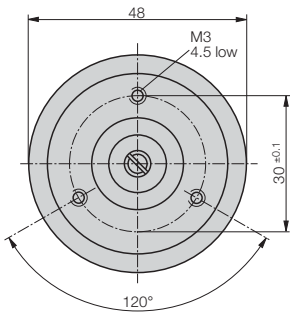

Fig. 7. KINAX 3W2 with shaft dia. 2 mm, length 12 mm.

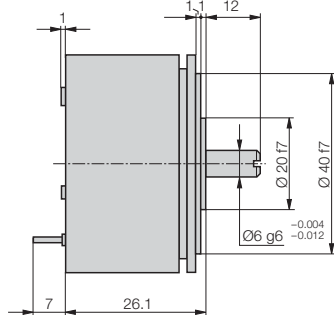

Fig. 8. KINAX 3W2 with shaft dia. 6 mm at front, length 12 mm, dia. 2 mm rear, length 6 mm.

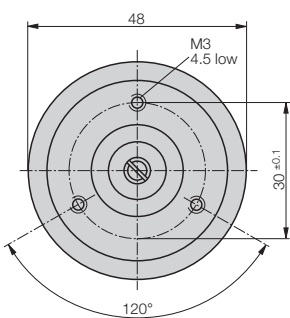

Fig. 9. KINAX 3W2 with shaft dia. 1/4", length 12 mm.

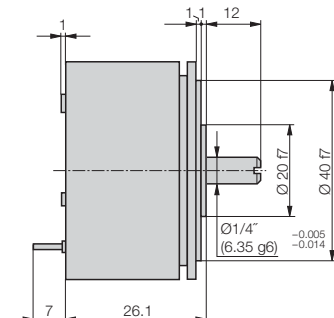

Fig. 10. KINAX 3W2 with shaft dia. 1/4", length 12 mm, dia. 2 mm rear, length 6 mm

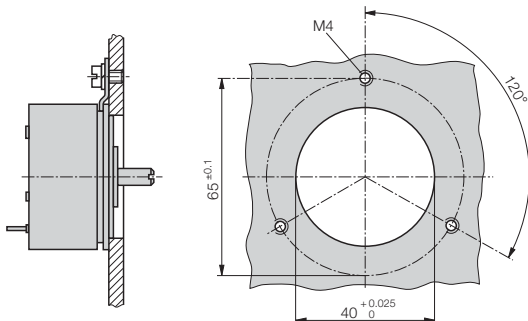

Fig. 11. Drilling plan for fixing with 3 spring clamps.

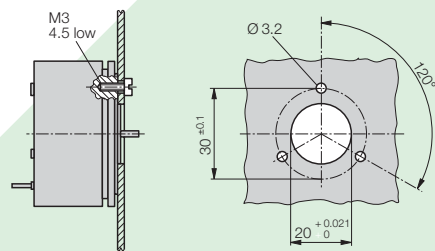

Fig. 12. Drilling plan for fixing with 3 cheesehead screws M3.

Standard accessories

- 3 clamps
- 1 Operating Instructions each in German, French and English
- 1 Ex approval (for instruments in Ex version only)

CAMILLE BAUER

Rely on us.

Camille Bauer Ltd
Aargauerstrasse 7
CH-5610 Wohlen / Switzerland
Phone: +41 56 618 21 11
Fax: +41 56 618 35 35
e-mail: info@camillebauer.com
www.camillebauer.com