

KINAX WT 710

Transmitter for Angular Position

Unit in field type housing

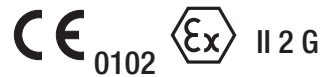

Application

The **KINAX WT 710** (Figs. 1 to 3) converts the angular position of a shaft into a **load-independent** direct current signal, proportional to the angular position. The unit is **contact free**. The compact housing has made this unit ideal for building onto other equipment and plant.

Features / Benefits

- Measuring input: Angular position

Measured variable	Measuring range limits
Angular position	0 ... 5° to 0 ... 270 °

- Measuring output: DC current signal (load-independent, 2, 3 or 4-wire connection)
- Potentiometer for adjusting span / Optimum matching of desired measuring range
- Direction of rotation: Output signal increases for clockwise or counterclockwise rotation
- Capacitive scanning system / No wear and low annual maintenance
- Low influence from bearing play, < 0.1%
- Accuracy ≤ 0.5% for ranges ≤ 150°
- Torque < 0.001 Ncm
- Drive shaft fully rotatable without stops at instruments without additional gear
- Available with type of protection "Intrinsic safety" EEx ia IIC T6 / Can be mounted in hazardous area
- Unit in field type housing / Compact for building onto other equipment and plant



Fig. 1. KINAX WT 710 with shaft dia. 2 mm.



Fig. 2. Transmitter KINAX WT 710 and additional gear.

Technical data

Measuring input

Measured quantity: Angle of rotation α °

Measuring principle: Capacitive method
Differential capacitor with contact-free, non-wearing positional pick-up. Drive shaft fully rotatable without mechanical stops

Measuring ranges: 0 ... ≥ 5 to 0 ... ≤ 270 ° (without gear)
Preferred ranges
0...10, 0...30, 0...60, 0...90, 0...180 or 0...270 °
0...≥ 10 ° to 0...48 turns (with additional gear)



Fig. 3. Pressure gauge fitted with KINAX WT 710 transmitter.

KINAX WT 710

Transmitter for Angular Position

Drive shaft diameters: 2 or 6 mm resp. 1/4"

Frictional torque: < 0.001 Ncm with shaft dia. 2 mm
< 0.03 Ncm with shaft dia. 6 mm resp. 1/4", without additional gear.
Approx. 0.6 ... 3.2 Ncm with additional gear, depending on transmission ratio

Sense of rotation: Clockwise or counterclockwise (seen from the shaft side).
The same transmitter can be used for both directions of rotation. A switch has to be changed, however, to reverse the direction on transmitters with ranges 0...> 150 to 0...≤ 270 ↯°, see "Settings".

Measuring output $\ominus \rightarrow$

Output variable I_A : Load-independent DC current, proportional to the input angle

Zero point correction: Approx. ± 5%

Span adjustment: Approx. +5 / -30%, see "Feature 7"

Current limitation: I_A max. 40 mA

Standard ranges:

- 0...1 mA, 3 or 4-wire connection
- 0...5 mA, 3 or 4-wire connection
- 0...10 mA, 3 or 4-wire connection
- 4...20 mA, 2-wire connection
- 0...20 mA, 3 or 4-wire connection adjustable with potentiometer
- 4...20 mA, 3 or 4-wire connection
- 0...20 mA, 4-wire connection

Non-standard ranges: 0...> 1.00 to 0...< 20 mA
3 or 4-wire connection

External resistance (load): $R_{ext} \text{ max. [k}\Omega\text{]} = \frac{12 \text{ V}}{I_A \text{ [mA]}}$
(for instruments with **DC-, AC** power supply by DC, AC power pack, **with** electric isolation)

$R_{ext} \text{ max. [k}\Omega\text{]} = \frac{H \text{ [V]} - 12 \text{ V}}{I_A \text{ [mA]}}$
(for instruments with **DC** power supply, **without** electric isolation)

I_A = Output signal end value

Residual ripple in output current: < 0.3% p.p.

Response time: < 5 ms

Accuracy

Reference value: Measuring range

Basic accuracy: Limit of error ≤ 0.5% for ranges 0...≤ 150 ↯°
Limit of error ≤ 1.5% for ranges from 0...> 150 to 0...270 ↯°

Reproducibility: < 0.2%

Reference conditions:

Ambient temperature 23 °C ± 2 K

Power supply H = 18 V

Output burden $R_{ext} = 0 \Omega$

Influence effects (maxima): (included in basic error)

Linearity error ± 0.4% for ranges 0...≤ 150 ↯°
± 1.4% for ranges from 0...> 150 to 0...270 ↯°

Dependence on external resistance $\Delta R_{ext} \text{ max.}$ ± 0.1%

Power supply influence ± 0.1%

Additional errors (maxima):

Temperature influence (-25...+ 70°C) ± 0.2% / 10 K

Bearing play influence ± 0.1%

Power supply H $\rightarrow \ominus$

DC and AC voltage: Nominal voltages and tolerances see "Table 1"

Table 1:

Nominal voltages U_N	Tolerances
24 ... 60 V DC/AC	DC - 15 ... + 33%
85 ... 230 V DC/AC	AC ± 15%

(only possible with standard version, non-Ex, **with** electric isolation, with DC, AC power pack (DC and 45...400 Hz)

Power consumption: < 0.9 W resp. < 1.8 VA

Power supply effect on accuracy: ≤ 0.1% within the admissible power supply tolerance

DC voltage **only**¹: 12...33 V
(possible with standard version, non-Ex, **without** electric isolation)
12...30 V
(necessary with **Ex** version, type of protection "intrinsic safety" EEx ia IIC T6, **without** electric isolation)

¹ Polarity reversal protection. The voltage must not fall below 12 V.

KINAX WT 710

Transmitter for Angular Position

Max. residual ripple:	10% p.p.	Intrinsic safety:	Acc. to EN 50 020: 1994
Max. current consumption:	Approx. 5 mA + I _A	Test voltage:	2.2 kVeff, 50 Hz, 1 min. between...
Power supply effect on accuracy:	≤ 0.2% within the admissible power supply tolerance		... power supply and housing ... power supply and measuring output (with DC, AC power supply, with electric isolation)

Mechanical withstand

Permissible vibration:	5 g every 2 h in 3 directions f ≤ 200 Hz		Housing protection:	IP 43 acc. to EN 60 529 without gear IP 64 with gear or other similar mounting	
Shock:	3 x 50 g 10 shocks each in 3 directions		Impulse voltage withstand:	1 kV, 1.2/50 μs, 0.5 Ws IEC 255-4, Cl. II	
Permissible static load on the shaft:	Drive shafts dia.	2 mm	6 mm	Permissible common-mode voltage:	100 V, 50 Hz
	Sense		resp. 1/4"		
	radial max.	16 N	83 N		
	axial max.	25 N	130 N		

Installation data

Dimensions:	See section "Dimensional drawings"		Environmental conditions
Housing:	Metal, cast aluminium Corrosion resistant finish Plastic protection cap		Climatic rating:
Mounting position:	Any		Standard version Temperature – 25 to + 70 °C Annual mean relative humidity ≤ 90%
Electrical connecting terminals:	Screw type terminals with indirect wire pressure, suited for max. 1,5 mm ² 2 glands PG 9, see "Feature 10."		or Version with improved climatic rating Temperature – 40 to + 70 °C Annual mean relative humidity ≤ 95%
Fixation:	3 cheesehead screws M3 or with 3 clamps		Ex-version Temperature – 40 to + 60 °C at T6 resp. – 40 to + 75 °C at T5
Weight:	Basic unit alone approx. 0.55 kg with additional gear approx. 0.9 kg		Transportation and storage temperature:
			– 40 to 80 °C

Regulations

Electromagnetic compatibility:	The standards EN 50 081-2 and EN 50 082-2 are observed
--------------------------------	--

Table 2: Data on explosion protection  II 2 G

Order Code	Type of protection "Intrinsic safety"		Certificates	Mounting location of the instrument
	Instrument	Marking		
710 - 2 ...	EEx ia IIC T6	Measuring output U _i = 30 V I _i = 160 mA P _i = 1 W C _i = 10 nF L _i = 0	Type Examination Certificate ZELM 99 ATEX 0006	Within the hazardous area

KINAX WT 710

Transmitter for Angular Position

Table 3: Specification and ordering information

Description	*Blocking code	No-go with blocking code	Article No./ Feature
KINAX WT 710 Order Code 710 - xxxx xxxx xxxx x			710 –
Feature, Selection			
1. Version of the transmitter			
Standard, measuring output not intrinsically safe	A		1
EEx ia IIC T6, measuring output intrinsically safe, CENELEC/ATEX	B		2
Other versions on request	B		9
2. Sense of rotation			
Calibrated for sense of rotation clockwise	D		1
Calibrated for sense of rotation counterclockwise	D		2
For “V” characteristic (“V” characteristic possible only without additional gear and without accessory kit for pressure gauge mounting)	E		3
Both senses of rotation, calibrated and marked (for measuring ranges $\leq 90^\circ$)	M		4
Lines 1 and 2: Instruments with ranges $0 \dots \geq 5$ to $0 \dots \leq 150 \text{ } \angle^\circ$ are usable in both senses of rotation. Instruments with ranges $0 \dots > 150$ to $0 \dots \leq 270 \text{ } \angle^\circ$ can be changed to the other direction. Chosen sense of rotation also applies for all versions with an additional gear!			
3. Measuring range (measuring input)			
$0 \dots 10 \text{ } \angle^\circ$		E	1
$0 \dots 30 \text{ } \angle^\circ$		E	2
$0 \dots 60 \text{ } \angle^\circ$		E	3
$0 \dots 90 \text{ } \angle^\circ$		E	4
$0 \dots 180 \text{ } \angle^\circ$		EM	5
$0 \dots 270 \text{ } \angle^\circ$		EM	6
Non-standard $0 \dots \geq 5$ to $0 \dots < 270 \text{ } \angle^\circ$ [\angle°]		E	9
With both senses of rotation calibrated, non-standard range: 0 to ≥ 5 to 0 to $< 90^\circ$			
“V” characteristic [$\pm \angle^\circ$]		DM	A
Specify start M_A and end M_E of measuring range! Observe the limits for ($M_A [\pm \angle^\circ] \geq 10$ and $M_E [\pm \angle^\circ] \leq 150$) and give both angles separated by an oblique stroke, e.g. [$\pm \angle^\circ$] 15/90!			
 <p>Example of a “V” characteristic for the measuring range [$\pm \angle^\circ$] 15/90 and measuring output range of $0 \dots 20$ mA</p>			

Table 3: Continued on next page!

KINAX WT 710

Transmitter for Angular Position

Description	*Blocking code	No-go with blocking code	Article No./ Feature
KINAX WT 710 Order Code 710 - xxxx xxxx xxxx x			710 –
Feature, Selection			
4. Output signal (measuring output) / Connecting version			
0 ... 1 mA / 3 or 4-wire connection			A
0 ... 5 mA / 3 or 4-wire connection			B
0 ... 10 mA / 3 or 4-wire connection			C
4 ... 20 mA / 2 wire connection or 0 ... 20 mA / 3 or 4-wire connection (adjustable with potentiometer)	H		D
4 ... 20 mA / 3 or 4-wire connection			E
0 ... 20 mA / 4-wire connection (only possible with DC, AC power supply (DC, AC power pack)	L	B	F
Non-standard, 3 or 4-wire connection			Z
0 ... > 1.00 to 0 ... < 20 [mA]			
Lines A to Z: R _{ext} max. see section "Technical data", 4-wire connection, with electric isolation only possible with DC, AC power supply (DC, AC power pack) 2, 3 or 4-wire connection, without electric isolation only possible with DC power supply.			
5. Power supply			
24 ... 60 V DC/AC, with electric isolation	F	BH	1
85 ... 230 V DC/AC, with electric isolation	F	BH	2
12 ... 33 V DC, without electric isolation	K	BL	A
12 ... 30 V DC (Ex), without electric isolation	K	AL	B
Lines 1 and 2: Not possible for DC, AC power supply at output! Version Ex only possible with line B!			1
6. Special features			
Without (order code complet)	Y		0
With The features to be omitted must be replaced by an oblique stroke (/) in the order code until reaching the required features			1
7. Settings (span adjustment)			
Extended setting range + 5% / – 60% Restriction: for angle ≥ 60°, supplementary error 0.2% (also possible on versions with additional gear)		Y	A
8. Drive shaft			
Drive shaft special dia. 6 mm, length 6 mm	N	Y	B
Drive shaft special dia. 1/4", length 6 mm Instead of the standard shaft dia. 2 mm, length 6 mm	N	Y	C
9. Improved climatic rating			
Standard version		BY	D
Ex versions		AY	E
10. Version with cable glands			
Locking plug instead of a second cable gland not possible with DC, AC power supply with electric isolation		FY	F

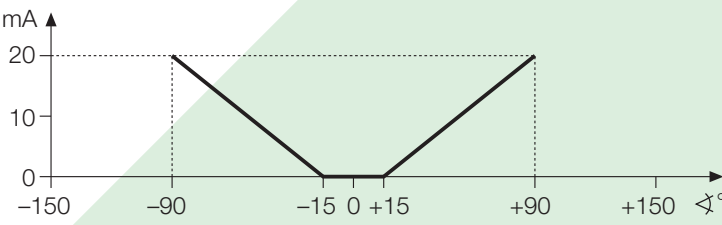
Table 3: Continued on next page!

KINAX WT 710 Transmitter for Angular Position

4-wire connection **with** electric isolation

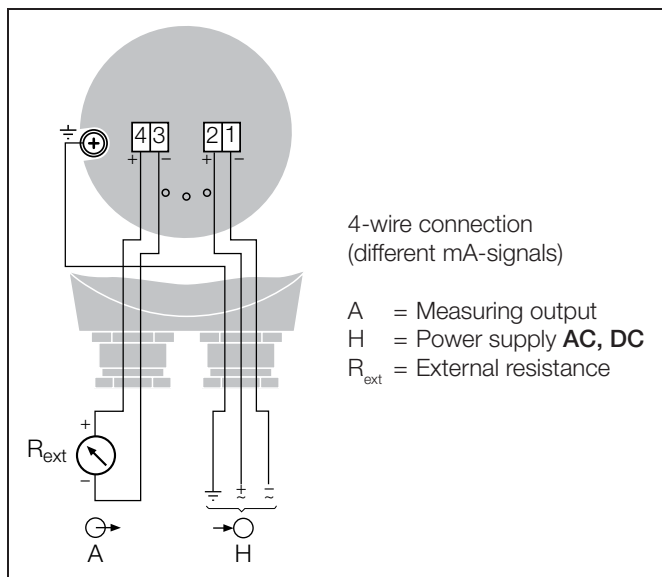

Settings

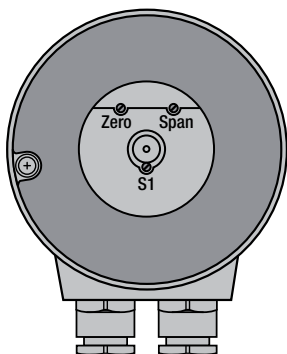

Fig. 4. Position of settings.

- ZERO = Potentiometer for zero point
SPAN = Potentiometer for measuring range end value
S1 = Switch for reversing direction of rotation for $\sphericalangle > 150^\circ$.

Transmitters with the ordering code 710 – ...D (see “Table 3: Specification and ordering information”) are designed for either a 2-wire connection with an output range of 4...20 mA or a 3 or 4-wire connection with an output range of 0...20 mA.

If, however, a transmitter be changed from one to the other (see “Electrical connections”) the beginning and end of the measuring range, ZERO and SPAN must be readjusted.

A switch is provided on angular transmitters with a measuring range $> 150^\circ$ for reversing the direction of rotation. It is marked S1.

Application

- Built onto measuring instruments with rotating pointer shafts, such as pressure gauges, vacuum gauges, absolute and differential pressure gauges as well as dial thermometers (liquid, vapour or mercury types).
- Built into actuator housings for position measurement, such as in valves, gates and butterfly valves.
- Built into transmission housing with float drive for liquid level measurements.
- Measurement of linear motion on coq-rails (racks), cylinders, sliding-carriages, floats, nozzle needles etc.



Fig. 5. Pressure gauge fitted with KINAX WT 710 measuring transmitter.



Fig. 6. KINAX WT 710 measuring transmitter and additional gear.

It is particularly suited for fitting on the back of measuring instruments with revolving indicator shaft, because its torque does not exceed 0.001 Ncm and therefore imposes hardly any interaction on the measuring instruments. The drive shaft is mounted in a ball bearing, eliminating friction almost completely. A flanged ring is supplied for mounting, and a driving fork with coupling lever for transmitting the measured value. Fig. 5 shows a pressure gauge with measuring transducer fitted, by way of example

By fitting an additional gear to the basic unit (see Fig. 6) the measuring range of the transducer can be largely adapted to the measuring duty. Gear ratios range from 1:4 and 64:1. Owing to friction in the gearing and drive shaft, however, this increases the torque to some 0.6 to 3.2 Ncm depending on the transmission ratio. Consequently this combination may be used only with equipment delivering sufficient torque.

Standard accessories

Transmitter:

- 3 clamps
- 1 protection cap
- 1 operating instructions, in three languages: German, French, English
- 1 Ex approval, for instruments in Ex version only

Transmitter for fitting on measuring instruments with revolving indicator shaft:

- 1 mounting ring
- 1 sealing ring
- 1 driving fork for 1.5 mm dia. on measuring instrument
- 1 coupling lever for 2 mm dia. on angle transmitter
- 3 clamps
- 3 screws M4 x 8
- 1 protection cap
- 1 operating instructions, in three languages: German, French, English
- 1 Ex approval, for instruments in Ex version only

Transmitter with additional gear:

- 3 clamps
- 1 mounting foot
- 2 screws M5 x 10
- 2 spring washer
- 1 operating instructions, in three languages: German, French, English
- 1 Ex approval, for instruments in Ex version only

KINAX WT 710

Transmitter for Angular Position

Dimensional drawings

Basic unit

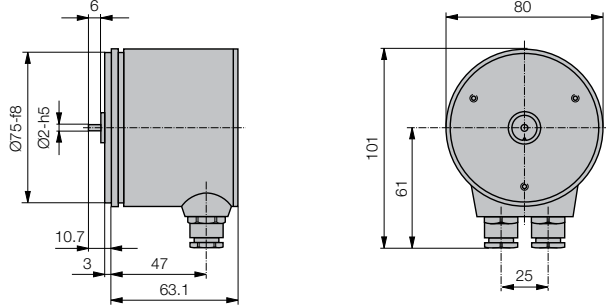

Fig. 7. Basic unit (fixation see Figs. 8 and 13).

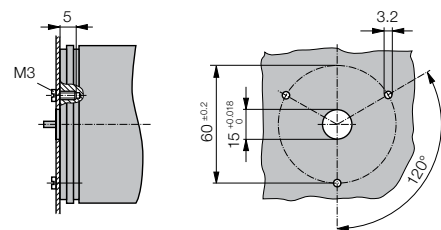

Fig. 8. Left: Fixing with cheesehead screws
Right: Drilling plan for cheesehead screws mounting.

Basic unit for fitting to measuring instruments with revolving indicator shaft

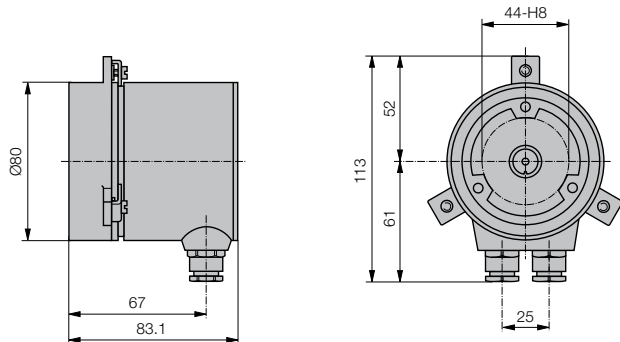

Fig. 9. Basic unit for fitting to measuring instruments with revolving indicator shaft. The measuring instrument must have an extended indicator shaft at the back (1.5 mm dia., length 6 ... 7 mm)

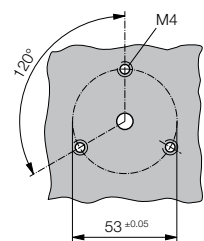

Fig. 10. Drilling plan for meas. instr. housing.

Basic unit with additional gear

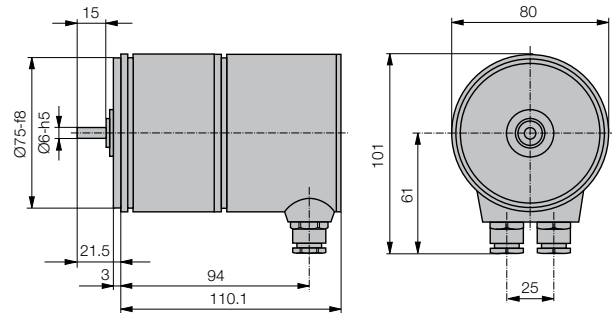

Fig. 12. Basic unit with additional gear (fixation see Fig. 13).

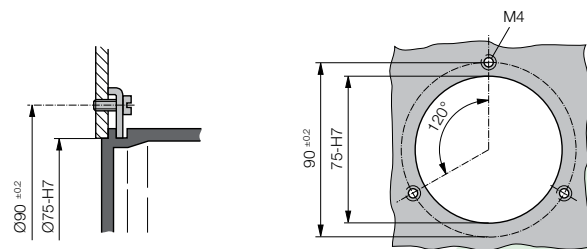

Fig. 13. Left: Fixing with clamps
Right: Drilling plan for clamp mounting.

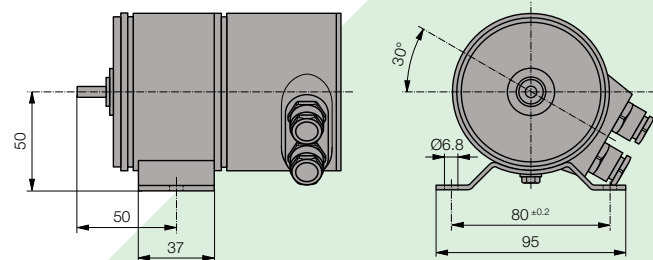

Fig. 14. Fixing with mounting foot.
(If the cable glands are in the way when mounted as above, the KINAX WT 710 should be rotate over 120°, after loosening the 3 screws holding the gear.)

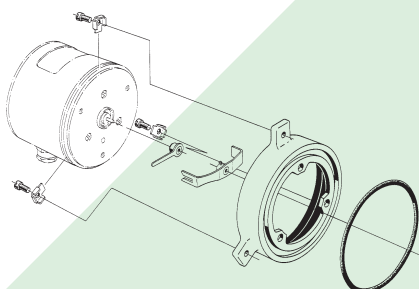

Fig. 11. Accessory kit for pressure gauge mounting (see "Feature 12")

CAMILLE BAUER

Rely on us.

Camille Bauer Ltd
Aargauerstrasse 7
CH-5610 Wohlen / Switzerland

Phone: +41 56 618 21 11

Fax: +41 56 618 35 35

e-mail: info@camillebauer.com

www.camillebauer.com