

# Operator's Manual DME406

Camille Bauer AG    All unauthorized use of this document  
CH-5610 Wohlen    will be legally prosecuted.



We reserve the right to make technical changes without notice!

## Contents

### 1. Overview

- 1.1 Modular Device Model
- 1.2 GSD Configuration

### 2. Product Description

- 2.1 Block Diagram
- 2.2 Technical Characteristics
- 2.3 Bus Connection

### 3. Technical Overview

- 3.1 Mapping of the Cyclic Data
- 3.2 Functions
- 3.3 System data
- 3.4 Device Model
- 3.5 IEEE 754 32 bit floating point format

### 4. Operating Modes

- 4.1 Local Mode (DP block = TRUE)
- 4.2 Master Mode (DP block = FALSE)

### 5. Operating Parameters (DDL<sub>M</sub>\_Set\_Prm)

- 5.1 Overview
- 5.2 GSD File
- 5.3 Connection type
- 5.4 Frequency measurement
- 5.5 Secondary Current (DME406 nominal current)
- 5.6 Primary Current (current converter nominal current)
- 5.7 Secondary Voltage (DME406 nominal voltage)
- 5.8 Primary Voltage (voltage converter nominal voltage)

### 6. Process Definition (DDL<sub>M</sub>\_Chk\_Cfg)

- 6.1 Format
- 6.2 Module Overview

### 7. Special Module

- 7.1 Meters (Module 47)
- 7.2 Control (Module 128)

### 8. Diagnosis (DDL<sub>M</sub>\_get\_diag)

- 8.1 Overview
- 8.2 Station\_status
- 8.3 Master\_Add
- 8.4 Ident\_Number
- 8.5 Ext\_Diag\_Data

### 9. Bus Interface

### 10. Revision

Change	Date	Ini.:	Type:	DME406	No.: 1/16	Date: 08.06.04	ThK
2005-050	8.12.05	RR	Designation:	<b>Operator's Manual</b>	Doc. Nr.:	W 2411	e

## 1. Overview

# Programmable Multi-Transducer for High-Power Systems with PROFIBUS DP

- Measurement of current, voltage, active, reactive and apparent power, and power factor, frequency and energy.
- Accuracy class 0.2
- The ratios of the current and voltage converters are configurable.
- Compact construction for top-hat rail or panel mounting.
- Standard Profibus DP with up to 12 Mbit/sec.
- Additional configuration software is not necessary.



- Plug & Play: On replacing the device, the engineered configuration is automatically taken over.
- All the device parameters are configurable via the DP Master.
- Economic engineering, installation and commissioning.
- Remote operation and fast error diagnosis supports preventive maintenance and therefore shorter outages.
- Flexibility: On changes to the requirements, the configuration parameters can be changed via the control system.

### 1.1 Modular Device Model

As for all bus systems, the transmission of the smallest possible amount of useful data from each bus partner is an important criterion for the performance of the complete network. Profibus DP works with a fixed process definition that is polled cyclically by the DP Master. For a multi-variable device this signifies that in each bus cycle all the variables are transmitted, although the corresponding application only possibly requires one measurand. With the DME406 each measurand is allocated to a module, so that the user has the possibility to select individual modules and to configure the station. During the engineering of the system, only the DME406 modules that are effectively required are configured in the slave station window.

### 1.2 GSD Configuration

With the GSD file loaded, all the device parameters can be configured with the control system engineering tool. If a device is replaced, only the device address must be set, either with the function "Set\_Slave\_Address" or locally via the RS232 interface. All other parameters are taken from the DP Master at the start of cyclic communication. This means that there is no extensive local configuration.

Naturally there is also the possibility to locally configure or simply read out the current settings of the device.

Change	Date	Ini.:	Type: DME406	No.: 2/16	Date: 08.06.04 ThK
2005-050	8.12.05	RR	Designation: <b>Operator's Manual</b>	Doc. Nr.:	W 2411 e

## 2. Product Description

The SINEAX DME 406 is a programmable multi-transducer for high-power systems with PROFIBUS DP.

### 2.1 Block Diagram

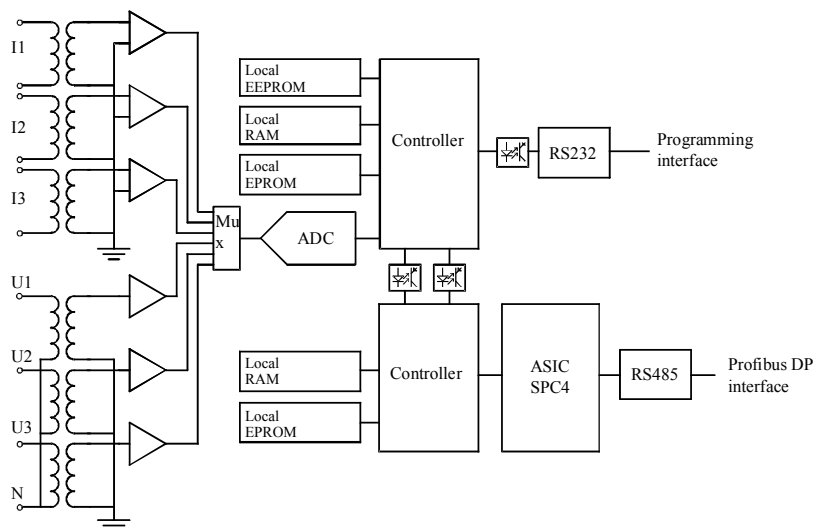

### 2.2 Technical Characteristics

Nominal frequency 50, 60, 16 2/3 Hz  
 Input voltage 57 to 400 V (L-N)  
 Input current 1 to 6A

Accuracy 0.2%  
 Power supply 24...60V AC/DC  
 85...230V AC/DC

#### Terminal allocation

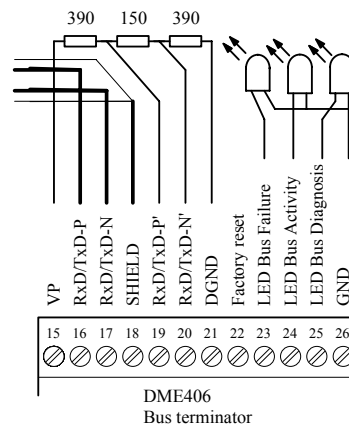
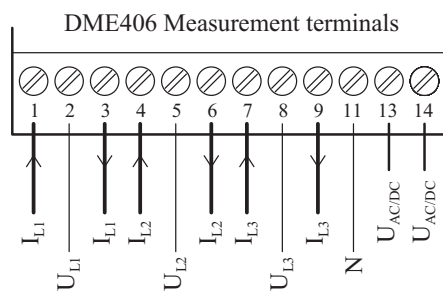

### Conductor terminations

Both ends of the bus cable must be fitted with a bus terminator. This ensures that:

- the conductors have a fixed no-load voltage,
- reflections in the cable are minimized and
- the bus has an almost constant load.

### LEDs

LED Bus Failure -> The slave is in the state "Baud Search" and does not receive valid telegrams  
 LED Bus Diagnosis -> flashes for every correctly received item  
 LED Bus Active -> Lit: Parameter error Flashing: Configuration error

### Factory Reset

To reset the device to the default status, set this connection to GND for 3 secs.

REAL\_NO\_ADD\_CHANGE = FALSE

SLAVE\_ADDRESS = 126

The factory reset has no influence on the programmed types of measurands and configuration.

Change	Date	Ini.:	Type:	DME406	No.:	3/16	Date:	08.06.04	ThK
2005-050	8.12.05	RR	Designation:	<b>Operator's Manual</b>	Doc. Nr.:	W 2411 e			

### 2.3 Bus Connection

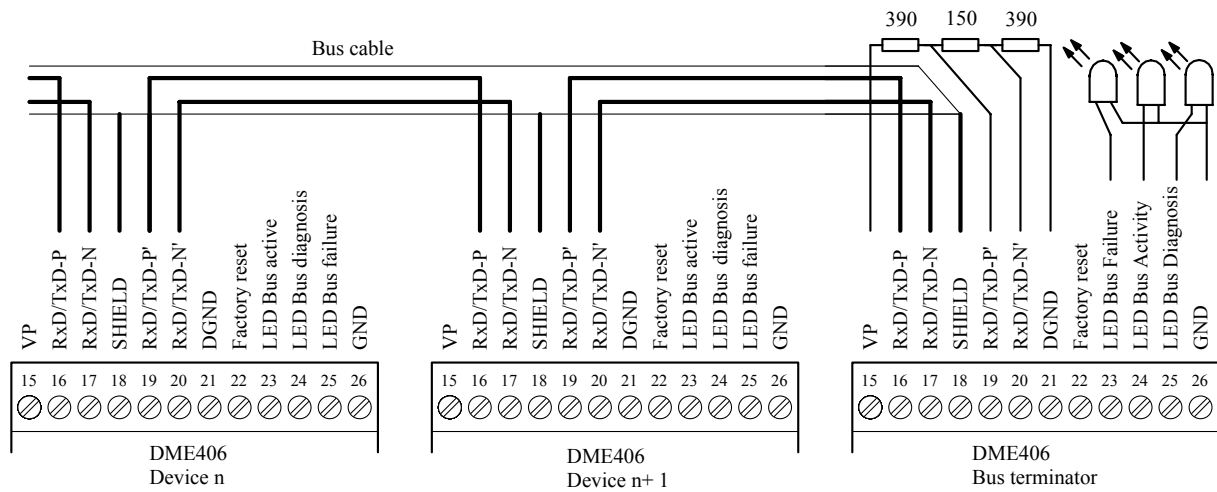

## 3. Technical Overview

The DME406 is exclusively a Profibus DP device. This means that the measurands can only be *accessed cyclically*.

### 3.1 Mapping of the Cyclic Data

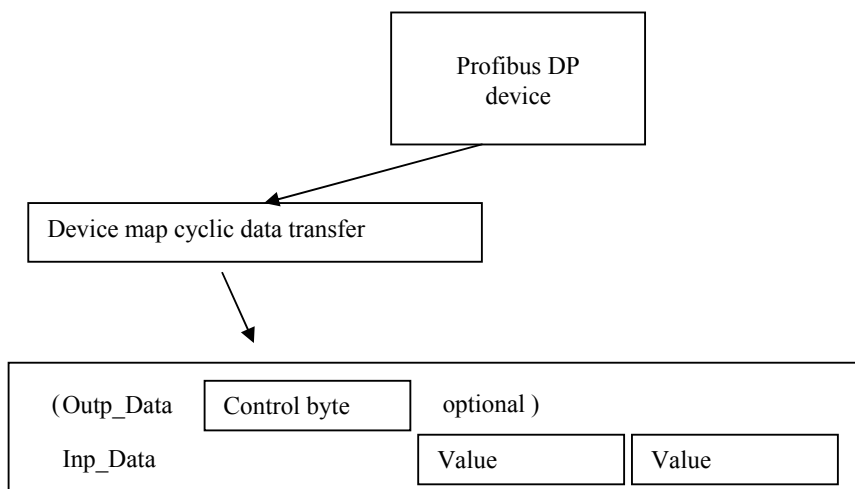

### 3.2 Functions

Default SAP	Data exchange
SAP55	Change station address
SAP56	Read inputs
SAP57	Read outputs
SAP58	Control command
SAP59	Read configuration
SAP60	Read diagnosis
SAP61	Configure the device
SAP62	Check the configuration

### 3.3 System data

Protocol	Profibus DP EN50170
Protocol chip	SPC4
Transmission rate	9.6 kbaud...12 Mbaud
	automatic baud rate detection or fixed configured
Address	126 (default), via Set_Slave_Address or can be set locally
Max. bus length	100..1200m (dependent on baud rate/cable)
Interface	RS485, galvanically isolated (500V)
Bus connection	Screw terminals
Config. possibilities	Locally via PC or via bus master

Change	Date	Ini.:	Type:	DME406	No.:	4/16	Date:	08.06.04	ThK
2005-050	8.12.05	RR	Designation:	<b>Operator's Manual</b>	Doc. Nr.:	W 2411 e			

### 3.4 Device Model

The DME406 is physically a compact multi-variable device that measures up to 47 measurands. However, in the control system, the DME406 is treated as a modular device that supplies exactly one measurand per module (slot). This allows the process definition to be adapted exactly to the application and allows the cyclic telegrams to be configured as short as possible. Each additional module (each measurand) increases the size of the cyclic response telegram by 4 bytes. To identify the module, the module number is simply used in the "Identifier Format" of the configuration telegram.

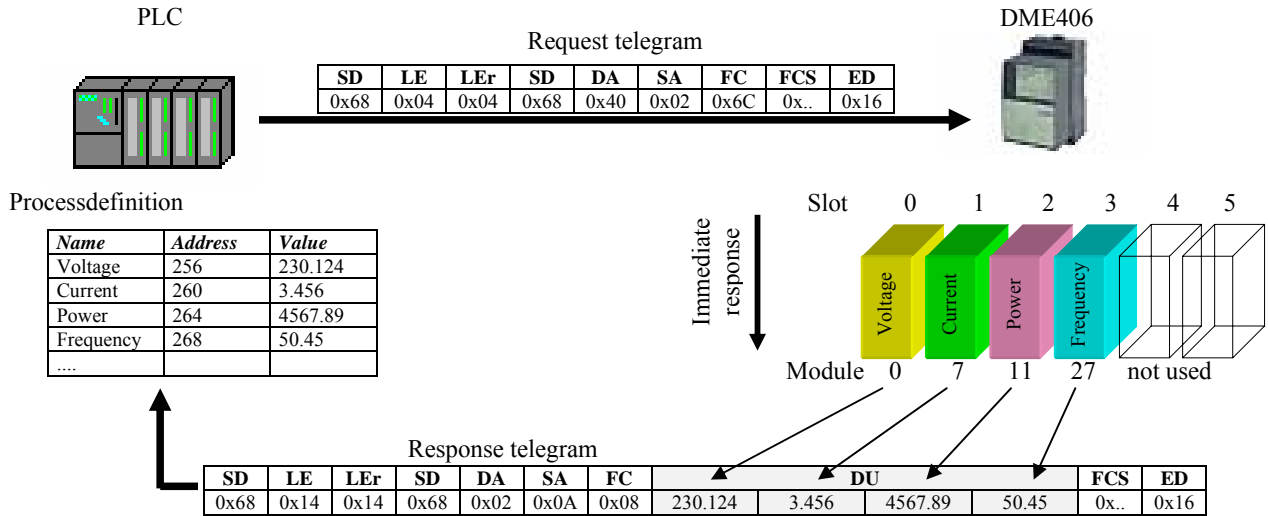

Designation	Symbol	Module
System voltage	U	0
Phase to neutral voltage L1 - N	U1N	1
Phase to neutral voltage L2 - N	U2N	2
Phase to neutral voltage L3 - N	U3N	3
Phase to phase voltage L1 - L2	U12	4
Phase to phase voltage L2 - L3	U23	5
Phase to phase voltage L1 - L3	U13	6
System current	I	7
Current phase 1	I1	8
Current phase 2	I2	9
Current phase 3	I3	10
System active power	P	11
Active power phase 1	P1	12
Active power phase 2	P2	13
Active power phase 3	P3	14
System reactive power	Q	15
Reactive power phase 1	Q1	16
Reactive power phase 2	Q2	17
Reactive power phase 3	Q3	18
System active power factor	PF	19
Active power factor phase 1	PF1	20
Active power factor phase 2	PF2	21
Active power factor phase 3	PF3	22
System reactive power factor	QF	23

Designation	Symbol	Module
Reactive power factor phase 1	QF1	24
Reactive power factor phase 2	QF2	25
Reactive power factor phase 3	QF3	26
System frequency	F	27
System apparent power	S	28
Apparent power phase 1	S1	29
Apparent power phase 2	S2	30
Apparent power phase 3	S3	31
Current mean value	IM	32
Signed current mean value	IMS	33
System power factor	LF	34
Power factor phase 1	LF1	35
Power factor phase 2	LF2	36
Power factor phase 3	LF3	37
System current bimetal function	IB	38
Current bimetal function phase 1	IB1	39
Current bimetal function phase 2	IB2	40
Current bimetal function phase 3	IB3	41
System maximum current indicator	BS	42
Maximum current indicator phase 1	BS1	43
Maximum current indicator phase 2	BS2	44
Maximum current indicator phase 3	BS3	45
Voltage mean value	UM	46
Meters	Z	47
Control	C	128

### 3.5 IEEE 754 32 bit floating point format

By using the floating-point format, all the measurands can be directly represented in the control system without being scaled. The byte order can be inverted by the Control-Modul.

Byte n		Byte n+1				Byte n+2				Byte n+3						
B7	Bit 6	Bit 0			B7	Bit 6	Bit 0			Bit 7	Bit 0					
vz	2 <sup>7</sup>	2 <sup>6</sup>	2 <sup>5</sup>	2 <sup>4</sup>	2 <sup>3</sup>	2 <sup>2</sup>	2 <sup>1</sup>	2 <sup>0</sup>	2 <sup>7</sup>	2 <sup>6</sup>	2 <sup>5</sup>	2 <sup>4</sup>	2 <sup>3</sup>	2 <sup>2</sup>	2 <sup>1</sup>	2 <sup>0</sup>
N	Exponent							Mantissa								

Formula: value =  $(-1)^N \times 2^{(\text{exponent} - 127)} \times (1 + \text{mantissa})$   
 Example: 40 F0 00 00 h = 0100 0000 1111 0000 0000 0000 0000 0000 b  
 =  $(-1)^0 \times 2^{(129-127)} \times (1 + 0.875)$   
 = 7.5

Change	Date	Ini.:	Type:	DME406	No.:	5/16	Date:	08.06.04	ThK
2005-050	8.12.05	RR	Designation:	<b>Operator's Manual</b>	Doc. Nr.:	W 2411 e			

## 4. Operating Modes

### 4.1 Local Mode (DP block = TRUE)

The DME406 is configured locally with the DME4 configuration software.

The connection type, measurands, device address and the baud rate are set locally and cannot be modified by the control system (function Set\_Slave\_Address is blocked).

#### Parameter telegram:

The User\_Prm\_Daten in the parameter telegram from the master are not used and instead the local connection type is used. If User\_Prm\_Len > 18, the flag Diag.prm\_fault is set in the diagnosis data.

#### Configuration telegram:

The simple "Identifier Byte" and also the "Identifier Format" are accepted. However, the identifier information is not used and there is a plausibility check only on the number of bytes received. If the number is not a multiple of 4 (size of (float)), or if the number is greater than the number of measurands to be transmitted, the number of measured variables, the flag Diag.cfg\_fault is set in the diagnosis data.

The current configuration can be read with the function "Get\_Cfg".

#### Cyclic data exchange:

The measurands are arranged in the same order in the cyclic telegrams as they are defined in the DME4 configuration software.

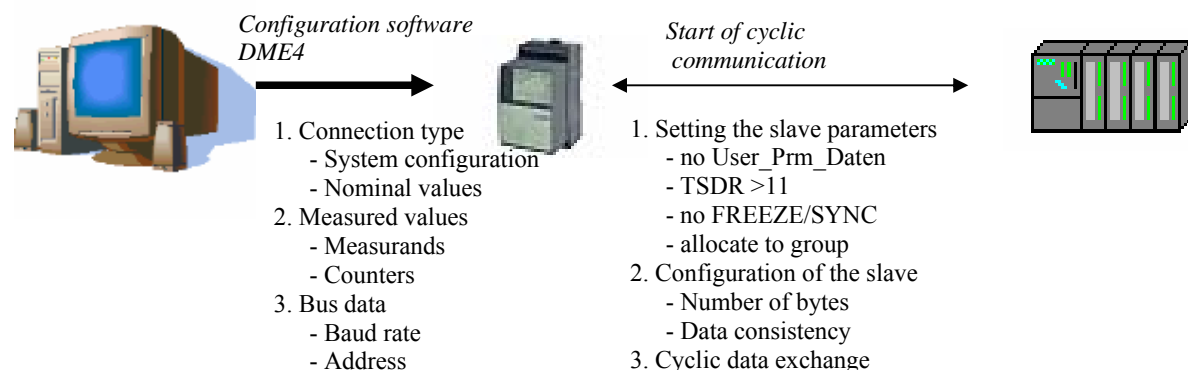

### 4.2 Master Mode (DP block = FALSE)

The connection type, measurands, device address and the baud rate are set via the DP Master C1.

All the parameters necessary for operation are set at the control system with the engineering tool using the loaded GSD file CAMBE406.gsd and are transmitted to the DME406 at startup with the functions "Set\_Slave\_Address", "Set\_Prm" and "Chk\_Cfg". At each initialization of the bus system, the DME406 takes over the connection type and measurands from the master. Only the baud rate and the address can be set locally. At the factory the baud rate is set to "BaudSearch" so that the DME406 automatically detects the baud rate used in the network and the device address is set to 126. The address can be changed locally or with the function "Set\_Slave\_Address". Therefore no special configuration software is necessary.

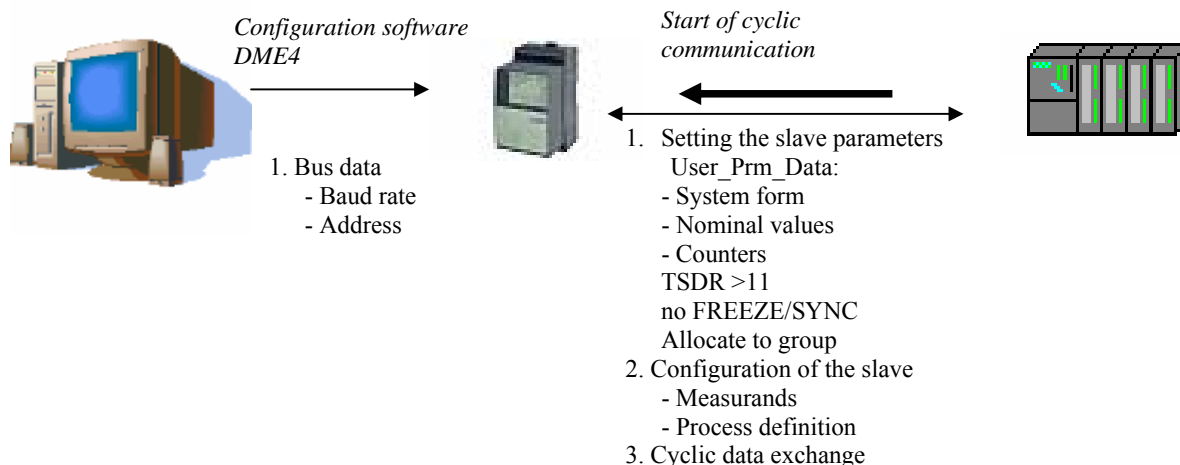

Change	Date	Ini.:	Type:	DME406	No.:	6/16	Date:	08.06.04	ThK
2005-050	8.12.05	RR	Designation:	<b>Operator's Manual</b>	Doc. Nr.:	W 2411	e		

## 5. Operating Parameters (DDL\_M\_Set\_Prm)

With the function Set\_Prm, in addition to the parameters described in the DP standard, manufacturer specific operating parameters (User\_Prm\_Data) can also be transmitted. These are characterized in that they are transmitted once from the master to the slave at the start of communication. Normally, the adjustable operating parameters can be presented in text form with the DP master configuration tool by reading the DME406 GSD file. With User\_Prm\_Data the following operating parameters can be set. In local mode the User\_Prm\_Data 0 to 17 are not evaluated.

### 5.1 Overview

Parameter	Data type	Byte number	Standard value	Class
Station status	8 bit	1	88h	EN50170
Response monitoring time	16 bit	2-3	340ms	EN50170
Min. station delay responder	8 bit	4	11	EN50170
PNO-Ident-Number	16 bit	5-6	E406h	EN50170
Group_Ident	8 bit	7	0	EN50170
Primary voltage (voltage converter nominal voltage)	32 bit	8-11	0	User_Prm_Data_0 – User_Prm_Data_3
Secondary voltage (DME406 nominal voltage)	16 bit	12-13	230	User_Prm_Data_4 – User_Prm_Data_5
Primary current (voltage converter nominal current)	32 bit	14-17	0	User_Prm_Data_6 – User_Prm_Data_9
Secondary current (DME406 nominal current)	16 bit	18-19	5000	User_Prm_Data_10 – User_Prm_Data_11
Frequency measurement	8 bit	20	42h	User_Prm_Data_12
Connection type	8 bit	21	20h	User_Prm_Data_13
Meter *	8 bit	22	0	User_Prm_Data_14
Meter *	8 bit	23	0	User_Prm_Data_15
Meter *	8 bit	24	0	User_Prm_Data_16
Meter *	8 bit	25	0	User_Prm_Data_17

\* Meters are module specific user parameters and are only available if the counter module is used.

### 5.2 GSD File

The GSD file for the DP slave (DME406) contains the device characteristics for the DP components. For example, it defines which baud rates and special DP modes are supported by the slave. Each master requires the associated GSD file in order to uniquely identify the slave on the bus.

The file CAMBE406.gsd corresponds to the GSD specification revision 3. If the control system engineering tool can only read revision 2 files, certain key words must be removed by redefining them as comments. As the new key words in revision 3 only concern the functional extension of the DPV1 and PA devices, this is possible without any problem.

### Information

The DME406 GSD file (*CAMBE406.gsd*) is available free for download from [www.camillebauer.com](http://www.camillebauer.com).

Change	Date	Ini.:	Type:	DME406	No.:	7/16	Date:	08.06.04	ThK
2005-050	8.12.05	RR	Designation:	<b>Operator's Manual</b>	Doc. Nr.:	W 2411	e		

Byte	<b>21</b>
Bit	7 – 0
Data	$2^7 - 2^0$
<i>5.3 Connection type</i>	

Contains the transducer connection type. From this, the measurands that can be evaluated respectively those that are valid for the measurand display can be determined.

Bit	Designation	Standard value	Description
0	A11	0	Single phase AC
1	A13	0	Three-wire, 3-phase, symmetric load
2	A14	0	Four-wire, 3-phase, symmetric load
3	A24	0	Four-wire, 3-phase, open-Y connection
4	A34	0	Three-wire, 3-phase, aron connection
5	A44	1	Four-wire, 3-phase, asymmetric load
6	A12	0	As A13, but with U measurement U1-2
7	A15	0	As A13, but with U measurement U3-1
6,7	A16	0	As A13, but with U measurement U2-3

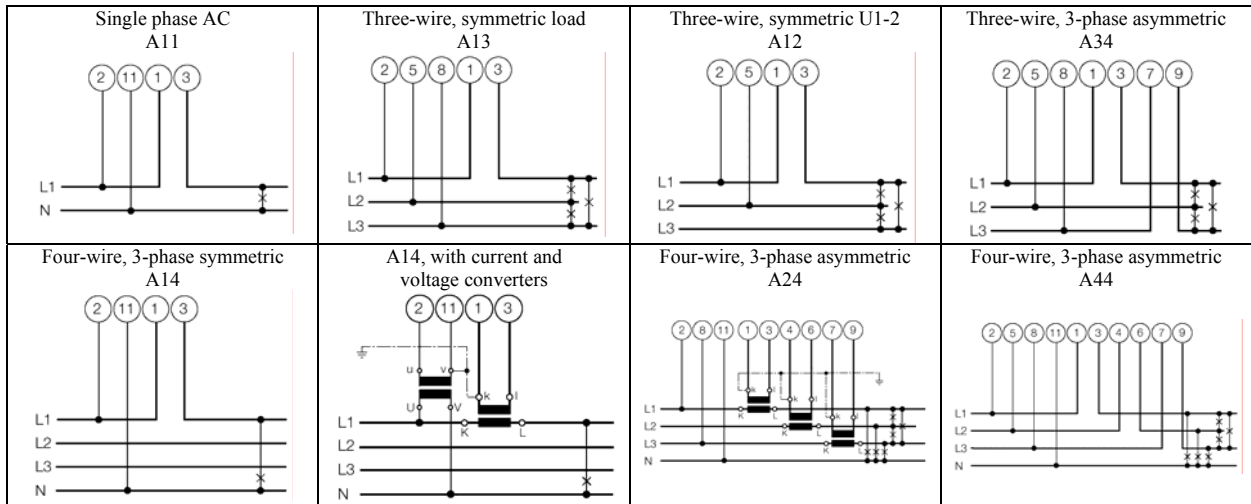

Byte	<b>20</b>
Bit	7 – 0
Data	$2^7 - 2^0$
<i>5.4 Frequency measurement</i>	

Defines the nominal frequency and the type of frequency measurement. As default, the frequency is measured via the voltage path. If the voltage connection is not available or if it is unstable, the measurement can be made via the current path. During configuration, the nominal frequency should be compared with the calibration frequency. These frequencies should match, otherwise additional errors must be accepted.

Bit	Designation	Standard value	Description
0	16 2/3 Hz	0	Nominal frequency 16 2/3 Hz
1	50 Hz	1	Nominal frequency 50 Hz
2	60 Hz	0	Nominal frequency 60 Hz
6	U path	1	Frequency measurement via U path
7	I path	0	Frequency measurement via I path

Change	Date	Ini.:	Type:	DME406	No.:	8/16	Date:	08.06.04	ThK
2005-050	8.12.05	RR	Designation:	<b>Operator's Manual</b>	Doc. Nr.:	W 2411 e			

The parameters secondary / primary current and secondary / primary voltage determine the conversion ratio of the current and voltage converters. The effective measurand value is calculated according to the formula:

$$I_{\text{system}} = \text{measured value} \cdot \frac{I_{\text{primary current}}}{I_{\text{secondary current}}} \quad U_{\text{system}} = \text{measured value} \cdot \frac{U_{\text{primary voltage}}}{U_{\text{secondary voltage}}}$$

Byte	<b>18</b>	<b>19</b>
Bit	15 – 8	7 – 0
Data	$2^{15} - 2^8$	$2^7 - 2^0$
<i>5.5 Secondary Current (DME406 nominal current)</i>		

Measured value of the input current. The secondary current can be 0 or 1000...6000 [mA].

Byte	<b>14</b>	<b>15</b>	<b>16</b>	<b>17</b>
Bit	32 – 24	23 – 9	15 – 8	7 – 0
Date	$2^{32} - 2^{24}$	$2^{23} - 2^{16}$	$2^{15} - 2^8$	$2^7 - 2^0$
<i>5.6 Primary Current (current converter nominal current)</i>				

Defines the primary current in [A] of the input converter. If there is no converter, set the value to 0, otherwise a maximum value of 200,000 A is permitted.

Byte	<b>12</b>	<b>13</b>
Bit	15 – 8	7 – 0
Data	$2^{15} - 2^8$	$2^7 - 2^0$
<i>5.7 Secondary Voltage (DME406 nominal voltage)</i>		

Measured value of the input voltage. The phase to neutral voltage is **always** given, even if, for example in a three-phase system only the phase to phase voltage is available. The secondary voltage corresponds to the voltage in [V], and is therefore in the range 57 ... 400V. If there is no voltage connection, 0 can be configured. In this case, the frequency measurement must be made via the current path (see "Frequency Measurement").

Byte	<b>8</b>	<b>9</b>	<b>10</b>	<b>11</b>
Bit	32 – 24	23 – 9	15 – 8	7 – 0
Data	$2^{32} - 2^{24}$	$2^{23} - 2^{16}$	$2^{15} - 2^8$	$2^7 - 2^0$
<i>5.8 Primary Voltage (voltage converter nominal voltage)</i>				

The primary nominal voltage of the voltage converter in [V]. If there is no voltage converter, the value is set to 0, otherwise a maximum value of 2,000,000 V is permitted.

Change	Date	Ini.:	Type:	DME406	No.:	9/16	Date:	08.06.04	ThK
2005-050	8.12.05	RR	Designation:	<b>Operator's Manual</b>	Doc. Nr.:	W 2411 e			

## 6. Process Definition (DDL\_M\_Chk\_Cfg)

### 6.1 Format

The configuration data transmitted with the Check\_Cfg function determine which process data are exchanged by the Data\_Exchange function.

There are two configuration data formats: the general identification format (Identifier Byte) and the special identification format (Identifier Format). In local mode the DME406 accepts both formats, but in master mode it only accepts and uses the special identification format to identify the module as used in the file CAMBE406.gsd.

If the necessary modules are inserted in the slave station window with the DP Master configuration tool, the corresponding configuration data and therefore the process definition are made at the same time. If a module (measurement) is defined that does not exist in the corresponding connection type, the flag Diag.cfg\_fault is set.

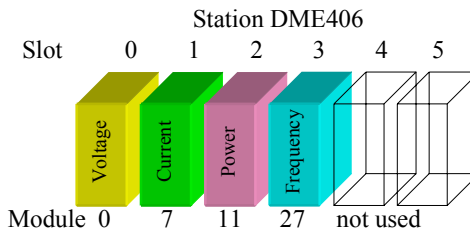

Chk Cfg telegram

SD	LE	LEr	SD	DA	SA	FC	DSA	SSA	Cfg_Data				FCS	ED
0x68	0x12	0x12	0x68	0x8A	0x82	0x68	0x3E	0x3C	0x41 0x83 0	0x41 0x83 7	0x41 0x83 11	0x41 0x83 27	0x..	0x16

Byte x								Byte x + 1							
0	1	0	0	0	0	0	1	1	0	0	0	0	0	1	1
Input / output								Consistency							
Fixed at 0								0 = byte, 1 = word							
Fixed at 0								Length of the IO data							
Length of the manufacturer specific data								0 = 1 byte / word							
								63 = 64 bytes / words							

Consistency

0	Consistency over byte / word
1	Consistency over total length

Input / output

00	Special identification format
01	Input
10	Output
11	Input / output

In local mode the DME406 also accepts the simple identification format:

Byte 1...x							
Consistency							
0 = byte, 1 = word							
Input / output							
Data length							
00 = 1 byte / word							
15 = 16 bytes / words							

Change	Date	Ini.:	Type:	DME406	No.: 10/16	Date: 08.06.04	ThK
2005-050	8.12.05	RR	Designation:	<b>Operator's Manual</b>	Doc. Nr.:	W 2411 e	

## 6.2 Module Overview

Designation	Symbol	Module	Unit	A11	A12	A13	A14	A15	A16	A24	A34	A44
System voltage	U	0	V	✓	✓	✓	✓	✓	✓			
Phase to neutral voltage L1 - N	U1N	1	V							✓		✓
Phase to neutral voltage L2 - N	U2N	2	V							✓		✓
Phase to neutral voltage L3 - N	U3N	3	V							✓		✓
Phase to phase voltage L1 - L2	U12	4	V							✓	✓	✓
Phase to phase voltage L2 - L3	U23	5	V							✓	✓	✓
Phase to phase voltage L1 - L3	U13	6	V							✓	✓	✓
System current	I	7	A	✓	✓	✓	✓	✓	✓			
Current phase 1	I1	8	A							✓	✓	✓
Current phase 2	I2	9	A							✓	✓	✓
Current phase 3	I3	10	A							✓	✓	✓
System active power	P	11	W	✓	✓	✓	✓	✓	✓	✓	✓	✓
Active power phase 1	P1	12	W							✓	✓	✓
Active power phase 2	P2	13	W							✓	✓	✓
Active power phase 3	P3	14	W							✓	✓	✓
System reactive power	Q	15	VAR	✓	✓	✓	✓	✓	✓	✓	✓	✓
Reactive power phase 1	Q1	16	VAR							✓	✓	✓
Reactive power phase 2	Q2	17	VAR							✓	✓	✓
Reactive power phase 3	Q3	18	VAR							✓	✓	✓
System active power factor	PF	19		✓	✓	✓	✓	✓	✓	✓	✓	✓
Active power factor phase 1	PF1	20								✓		✓
Active power factor phase 2	PF2	21								✓		✓
Active power factor phase 3	PF3	22								✓		✓
System reactive power factor	QF	23		✓	✓	✓	✓	✓	✓	✓	✓	✓
Reactive power factor phase 1	QF1	24								✓		✓
Reactive power factor phase 2	QF2	25								✓		✓
Reactive power factor phase 3	QF3	26								✓		✓
System frequency	F	27	Hz	✓	✓	✓	✓	✓	✓	✓	✓	✓
System apparent power	S	28	VA	✓	✓	✓	✓	✓	✓	✓	✓	✓
Apparent power phase 1	S1	29	VA							✓		✓
Apparent power phase 2	S2	30	VA							✓		✓
Apparent power phase 3	S3	31	VA							✓		✓
Current mean value	IM	32	A							✓	✓	✓
Signed current mean value	IMS	33	A							✓	✓	✓
System power factor	LF	34		✓	✓	✓	✓	✓	✓	✓	✓	✓
Power factor phase 1	LF1	35								✓		✓
Power factor phase 2	LF2	36								✓		✓
Power factor phase 3	LF3	37								✓		✓
System current bimetal function	IB	38	A	✓	✓	✓	✓	✓	✓	✓	✓	✓
Current bimetal function phase 1	IB1	39	A							✓		✓
Current bimetal function phase 2	IB2	40	A							✓		✓
Current bimetal function phase 3	IB3	41	A							✓		✓
System current maximum indicator	BS	42	A	✓	✓	✓	✓	✓	✓	✓	✓	✓
Current maximum indicator phase 1	BS1	43	A							✓		✓
Current maximum indicator phase 2	BS2	44	A							✓		✓
Current maximum indicator phase 3	BS3	45	A							✓		✓
Mean value of the voltages	UM	46	V							✓		✓
Meters	M	47		✓	✓	✓	✓	✓	✓	✓	✓	✓
Update Counter	UC	48		✓	✓	✓	✓	✓	✓	✓	✓	✓
Control	C	128		✓	✓	✓	✓	✓	✓	✓	✓	✓

Change	Date	Ini.:	Type:	DME406	No.: 11/16	Date: 08.06.04 ThK
2005-050	8.12.05	RR	Designation:	<b>Operator's Manual</b>	Doc. Nr.:	W 2411 e

## 7. Special Module

### 7.1 Meters (Module 47)

The meter module has a module parameter that defines the measurand to be counted. As with the device specific operating parameters, this module parameter can also be displayed and modified as text when the GSD file is loaded. The module parameters are added to the device parameters with increasing slot numbers. The Set\_Prm telegram requires one byte for each counter module added (measurand No.). A maximum of 4 counter modules may be added!

#### Set Prm telegram

SD	LE	LEr	SD	DA	SA	FC	DSA	SSA	Prm_Data	FCS	ED		
0x68	0x1D	0x1D	0x68	0x8A	0x82	0x68	0x3D	0x3C	[21 bytes device specific operating parameter]	12	48	0x..	0x16

Symbol	No.
I	8
I1	9
I2	10
I3	11
S	29
S1	30
S2	31
S3	32
P incoming	12
P1 incoming	13
P2 incoming	14
P3 incoming	15

Symbol	No.
Q inductive	16
Q1 inductive	17
Q2 inductive	18
Q3 inductive	19
P outgoing	48
P1 outgoing	49
P2 outgoing	50
P3 outgoing	51
Q capacitive	52
Q1 capacitive	53
Q2 capacitive	54
Q3 capacitive	55

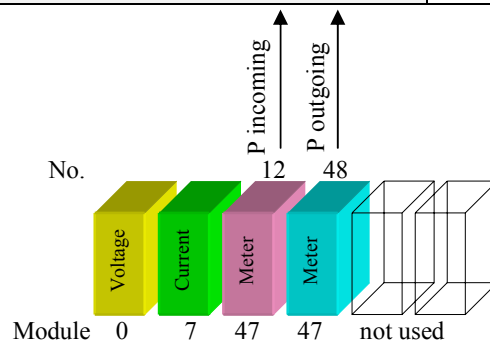

#### Chk Cfg telegram

SD	LE	LEr	SD	DA	SA	FC	DSA	SSA	Cfg_Data	FCS	ED
0x68	0x12	0x12	0x68	0x8A	0x82	0x68	0x3E	0x3C	0x41 0x83 0   0x41 0x83 7   0x41 0x83 47   0x41 0x83 47	0x..	0x16

Change	Date	Ini.:	Type:	DME406	No.:	12/16	Date:	08.06.04	ThK
2005-050	8.12.05	RR	Designation:	<b>Operator's Manual</b>	Doc. Nr.:	W 2411 e			

## 7.2 Control (Module 128)

The control module is for resetting the counters, slave pointers and the update counter and to change the data representation from the big-endian format to the little-endian format. It has no module parameters and occupies only 1 byte of output data in the cyclic process definition.

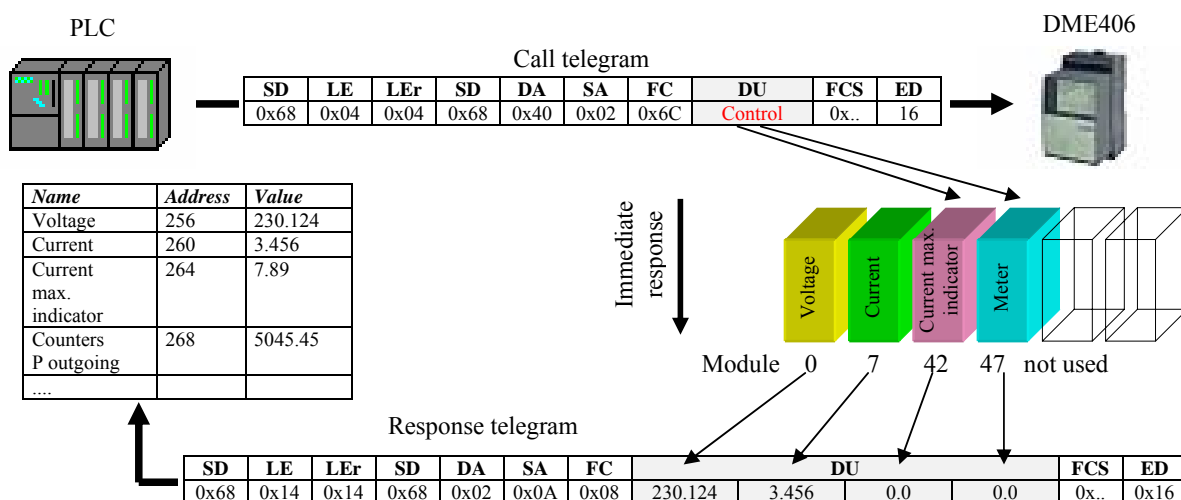

Byte	0
Bit	7 - 0
Data	$2^7 - 2^0$
	Control byte

Bit	Designation	Standard value	Description
0	Meter reset	0	The edge triggered flag „Meter reset“ resets all energy meters to 0. The negative transition takes no effect.
1	Slave pointer reset	0	The edge triggered flag „Slave pointer reset“ resets all slave pointers to 0. The negative transition takes no effect.
2	Update counter reset	0	The update counter monitors the update interval of the measurement unit. The update counter increments by 1 every time the measurands are updated. The update counter is represented by a floating point number, so it should be cleared before $2^{24} - 1 = 16777215$ , otherwise it stops.
3	Intel_Format	0	The Profibus specification defines the big-endian byte order for the transmission of IEEE754 floating point values. PC based automation more often use the little-endian format. The data representation is set to the little-endian format when the flag “Intel Format” is set. <b>Attention:</b> the flag takes effect not until after the next measurement update → the first transaction is always in the big-endian format. Byte order: 0 = big-endian; 1 = little-endian
4-7	Unused	0	Unused

Change	Date	Ini.:	Type:	DME406	No.:	13/16	Date:	08.06.04	ThK
2005-050	8.12.05	RR	Designation:	Operator's Manual	Doc. Nr.:	W 2411 e			

## 8. Diagnosis (DDL\_M\_get\_diag)

The PROFIBUS DP comprehensive diagnosis functions allow a fast localization of a fault. The evaluation of the diagnosis data via the control system depends on the support from the master.

### 8.1 Overview

Parameter	Data type	Byte number	Standard value	Class
Station_status	24 bit	1-3	0x000C00	EN50170
Master_Add	8 bit	4	FFh	EN50170
Ident_Number	16 bit	5-6	E406h	EN50170
Ext_Diag_Data	x bit	7-32	0	

Byte	1	2	3
Bit	7 - 0	15 - 8	23 - 16
Data	$2^7 - 2^0$	$2^{15} - 2^7$	$2^{23} - 2^{16}$
<i>8.2 Station_status</i>			

Bit	Designation	Default	Description
0	Station_Non_Existent	0	The DP master sets this bit when it cannot find the corresponding slave on the bus.
1	Station_Not_Ready	0	The DP slave sets this bit when it is not yet ready to exchange data.
2	Cfg_Fault	0	This bit is set immediately by the DP slave when it detects a difference between the configuration received and the configuration stored in the slave.
3	Ext_Diag	0	The DP slave indicates with this bit that diagnosis information in the user specific range (Ext_Diag_Data) is available, otherwise user specific low priority status information is available.
4	Not_Supported	0	The DP slave sets this bit when a function requested is not supported.
5	Invalid_Slave_Response	0	The DP master sets this bit on the reception of an implausible response.
6	Prm_Fault	0	The DP slave sets this bit when the last parameter telegram was incorrect. E.g. wrong length, wrong ident. number, invalid parameter.
7	Master_Lock	0	The slave has been parameterized by another master. This bit is set by the master (class 1) when the Master_Add is not equal to 255 and not equal to its own master address.
8	Prm_req	0	The slave requires a new start with a corresponding new parameterization and configuration. For example, when the system has been extended.
9	Stat_diag	0	The slave can no longer supply valid data. The master requests only diagnosis information until the flag is reset. E.g. failure of the power supply for the outputs.
10	1	1	The slave sets this bit.
11	WD_On	1	The DP slave sets this bit as soon as it has enabled the watchdog.
12	Freeze_Mode	0	The slave sets this bit after receiving a freeze command.
13	Sync_Mode	0	The slave sets this bit after receiving a sync. command.
14	reserved	0	reserved
15	Deactivated	0	The master sets this bit when it sets the slave to inactive and removes it from the data cycle. The slave always sets this bit to 0.
16-22	reserved	0	reserved
23	Ext_Diag_Overflow	0	The slave sets this bit when there is more diagnosis data in addition to the Ext_Diag_Data.

Change	Date	Ini.:	Type:	DME406	No.:	14/16	Date:	08.06.04	ThK
2005-050	8.12.05	RR	Designation:	<b>Operator's Manual</b>	Doc. Nr.:	W 2411 e			

Byte	<b>4</b>	
Bit	7 – 0	
Data	$2^7 - 2^0$	
	<i>8.3 Master_Add</i>	

The slave enters the address of the master that parameterized it in this field. If the slave is not yet parameterized the slave enters the address FFh.

Byte	<b>5</b>	<b>6</b>
Bit	15 – 8	7 – 0
Data	$2^{15} - 2^8$	$2^7 - 2^0$
	<i>8.4 Ident_Number</i>	

Each family of devices has a unique identification number. The slave only accepts the configuration if the Ident\_Number matches. The master can read this number to identify the device.

Byte	<b>7-32</b>	
Bit	200 – 0	
Data	$2^{25} - 2^0$	
	<i>8.5 Ext_Diag_Data</i>	

The DME406 has no device specific, module specific or channel-related diagnosis.

Change	Date	Ini.:	Type:	DME406	No.:	15/16	Date:	08.06.04	ThK
2005-050	8.12.05	RR	Designation:	<b>Operator's Manual</b>	Doc. Nr.:	W 2411 e			

## 9. Bus Interface

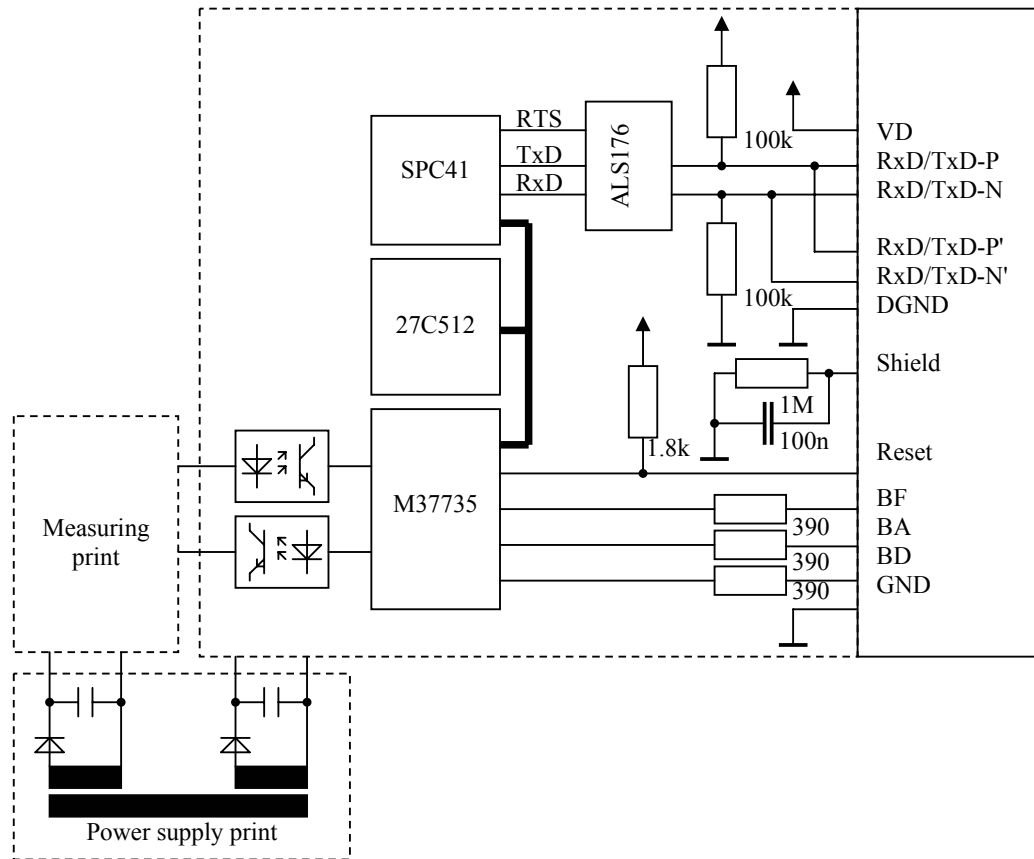

## 10. Revision

Date	Author	Firmware	Description
04.02.02	Th. K	1.04	- certified version
08.06.04	Th. K	1.05	- modul 48 (update counter) integrated - LED-pin definition BD, BF corrected/swapped - modul 47 (control) enhanced (clear update counter, little-endian) - measurands suppression by $U < 1V$ and $I < 10mA$

Change	Date	Ini.:	Type:	DME406	No.:	16/16	Date:	08.06.04	ThK
2005-050	8.12.05	RR	Designation:	<b>Operator's Manual</b>	Doc. Nr.:	W 2411	e		