

Safety precautions to be strictly observed are marked with following symbols in the Operating Instructions:



The instruments must only be disposed of in the correct way!

Operating Instructions

Programmable Temperature Transmitter SINEAX VK 616



Camille Bauer LTD
Aargauerstrasse 7
CH-5610 Wohlen/Switzerland
Phone +41 56 618 21 11
Fax +41 56 618 35 35
e-mail: info@camillebauer.com
http://www.camillebauer.com



VK 616 Be 142 125-02 10.09

Contents

1. Read first and then	1
2. Scope of supply	1
3. Brief description	1
4. Technical data	1
5. Securing the terminal head of the temperature sensor.....	2
6. Installation in the plant	2
7. Electrical connections	2
8. Configuring the transmitter	3
9. Commissioning.....	4
10. Maintenance.....	4
11. Accessories and spare parts.....	4
12. Dimensional drawings	4
13. Declaration of conformity	4

1. Read first and then ...



The proper and safe operation of the device assumes that the Operating Instructions are **read** and the safety warnings given in the various Sections

- 6. Installation in the plant
- 7. Electrical connections
- 8. Configuring the transmitter
- 9. Commissioning

are **observed**.

The device should only be handled by appropriately trained personnel who are familiar with it and authorised to work in electrical installations.

Unauthorized repair or alteration of the unit invalidates the warranty!

2. Scope of supply (Figs. 1 and 2)

Transmitter, one of the two versions (1)

Order Code: Significance of the 2nd. and 3rd. digits

616 - 7 x x
↑ ↑
1 Standard, not electrically isolated
2 Standard, electrically isolated
3 EEx ia IIC T6, not electrically isolated
4 EEx ia IIC T6, electrically isolated
0 Basic configuration programmed
1 Configured to order

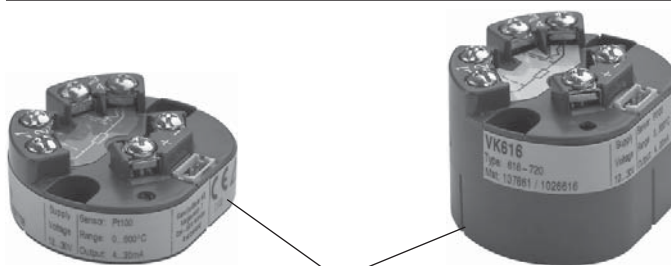

Fig. 1



Bild 2

- 1 **Operating Instructions** (2) each in German, French and English
- 1 **Type Examination Certificate** (3), (only for "intrinsically safe" explosion-proof devices)

3. Brief description

The programmable **SINEAX VK 616** is a two-wire head-mounted transmitter. It is designed for installation in the terminal head of a temperature sensor DIN 43 729, shape B.

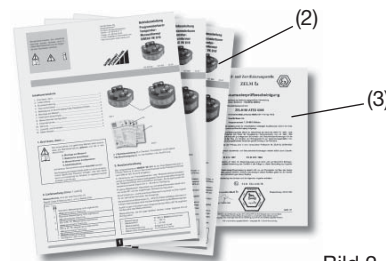
It is used for measuring temperature in conjunction with a thermocouple or resistance thermometer. Thermocouple non-linearities are automatically compensated. The output signal is a current in the range 4...20 mA.

The input, measuring range, signalling and other parameters are programmed with the aid of a PC and the corresponding software.

The sensor circuit is monitored for open and short-circuits and the output responds in a defined manner if one is detected.

The power supply of 12...30 VDC is connected together with the signal by the two leads connected to the measurement output (loop powered).

Explosion-proof "intrinsically safe" EEx ia IIC T6 versions rounds off the series of transmitters.

Transmitters supplied as standard versions are configured as follows:

- Measuring input:	Pt 100 for three -wire connection
- Measuring range:	0 ... 600 °C
- Measuring output:	4 ... 20 mA
- Open-circuit supervision:	Output 21.6 mA
- Mains ripple suppression:	For frequency 50 Hz

4. Technical data

Measuring input ⊖ ⊕ Input variable and measuring range configured

Input variables	Measuring ranges		
	Limits	Min. span	Max. span
Temperatures with resistance thermometers for two , three or four -wire connection			
Pt 100, IEC 60 751	-200 to 850°C	50 K	850 K
Ni 100, DIN 43 760	- 60 to 250°C	50 K	250 K
Temperatures with thermocouples			
Type B, E, J, K, N, R, S, T	acc. to type	2 mV	80 mV
acc. to IEC 60 584-1			
Type L and U, DIN 43 710			
Type W5 Re/W26 Re, Type W3 Re/W25 Re, acc. to ASTM E 988-90			

Cold junction compensation

Internal: Incorporated Pt 100 or with Pt 100 connected to the terminals

External: Via cold junction thermostat 0...60 °C, configurable

Measuring output (output/powering circuit)

Output signal IA: Impressed DC current, **linear with temperature**

Standard range: 4...20 mA, 2-wire technique

External resistance (load): $R_{ext\ max.} = \frac{\text{Power supply [V]} - 12\ \text{V}}{\text{Max. output current [mA]}}$

Load max. [Ω] with 20 mA output

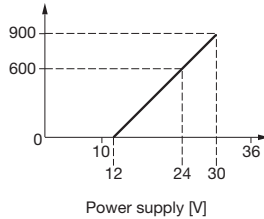

Programming connector on the transmitter

Interface: Serial interface

Open and short-circuit sensor circuit supervision

Signalling modes: Output signal configurable to...
 ... the value the output had immediately prior to the open or short-circuit* (hold value)
 ... a value between 4 and 21.6 mA
 * The short-circuit indicator is only active for the RTD $\geq 100\ \Omega$ at 0 °C, three and four-wire measuring mode

Power supply

DC voltage: Supply 12 ... 30 V DC
 max. residual ripple 1% p.p.
 (supply must not fall below 12 V)
 Protected against wrong polarity

5. Securing the terminal head of the temperature sensor

The **SINEAX VK 616** is suitable for mounting on an insert that is fitted into a temperature sensor with a Shape B DIN terminal head.

The length of the leads to the insert has to conform to the height of the particular terminal head (Figures 4 and 5).

Thread the leads through the hole in the centre of the transmitter. Align the transmitter in the lower part of the terminal head and secure it using two cheese-headed screws (1) and two springs (2) (see Fig. 3). Connect the leads acc. to section "7. Electrical connections".

7.1 Alternative measurement connections

Connect the measuring leads to suit the application as given in Table 1.

Table 1: Measuring input

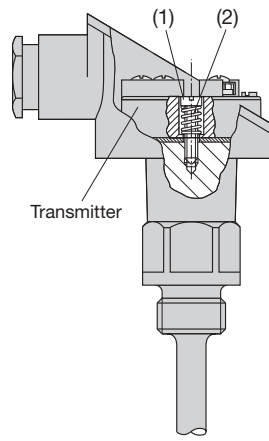
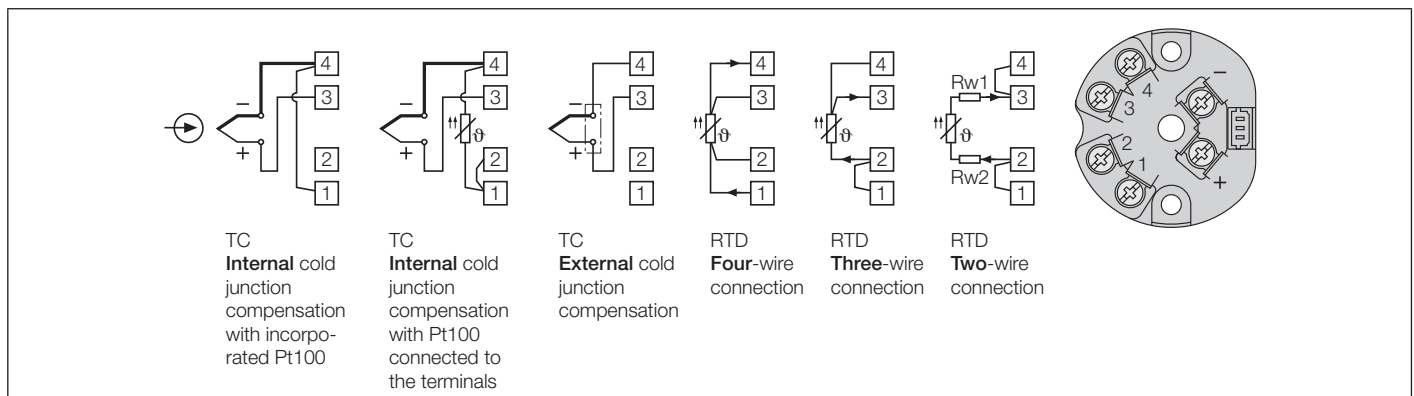

Fig. 3. Spring mounting on the insert in the terminal head.

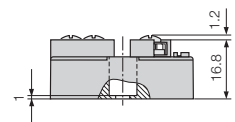

Fig. 4. SINEAX VK 616-71/73, not electrically isolated.

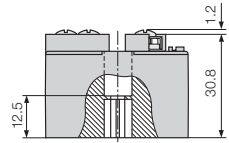

Fig. 5. SINEAX VK 616-72/74, electrically isolated.

6. Installation in the plant

Mount the thermometer transmitter according type (screwed, sliding terminal screws, flange etc.) at the prescribed location.



Make sure that the ambient temperature stays within the **permissible limits**:

Standard instruments: - 25 and + 80 °C

Ex version: - 25 to max. 57 °C (depending on P_i, see type examination certificate)!

7. Electrical connections

The leads are connected to the 6 Philips head screw terminals on the front of the transmitter. The maximum wire gauge is 2 x 1.5 mm², (see Fig. 6). The applicable enclosure Protection Class for the terminals is IP 00 according to EN 60 529.

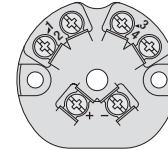

Fig. 6



Also note that, ...

... the data required to carry out the prescribed measurement must correspond to those marked on the nameplate of SINEAX VK 616 (Sensor, Range, Output, Supply Voltage) (see Fig. 8)!

... the total loop resistance connected to the output (receiver plus leads) **does not** exceed the maximum permissible value R_{ext}, see "Measuring output" in Section "4. Technical data"!

... the measurement input and output cables should be twisted pairs and run as far as possible away from heavy current cables!

In all other respects, observe all local regulations when selecting the type of electrical cable and installing them!



In the case of "Intrinsically safe" explosion-proof, the supplementary information given on the type examination certification, the EN 60 079-14, and also local regulations applicable to electrical installation in explosion hazard areas must be taken into account!



Notes:

7.1.1 Connection to thermocouples

Pay attention to correct polarity when connecting thermocouples. If the lead from the thermocouple to the transmitter has to be extended, be sure to use thermally compensated leads suitable for the particular type of thermocouple.

7.1.1.1 Internal cold junction compensation with incorporated Pt100

Connect terminals ① and ④ when using internal compensation by comparison.

Set the configuration software to "internal thermo-element" and "Pt100 built-in".

7.1.1.2 Internal cold junction compensation with Pt100 connected to the terminals

For this alternative, a Pt100 is connected to terminals ① and ④. Terminals ① and ② must be connected.

Set the configuration software to "internal thermo-element" and "Pt100 on terminals".

7.1.1.3 External cold junction compensation

When using a cold junction thermostat, please observe that the correct reference temperature is configured. The connection between the cold junction thermostat and the transducer is made with copper wires.

7.1.2 Connection to resistance thermometers

7.1.2.1 Two-wire connection

Terminals ① and ② and ③ and ④ must be connected in the case of a two-wire measurement.

The lead resistance must not be greater than 30 Ω per lead.

7.1.2.2 Three-wire connection

Terminals ① and ② must be connected in the case of a three-wire measurement. It is not necessary to compensate the leads, providing the three leads have identical resistances. The lead resistance must not be greater than 30 Ω per lead.

7.1.2.3 Four-wire connection

The four-wire measurement is independent of lead resistance within wide limits and therefore no compensation is necessary. The lead resistance must not be greater than 30 Ω per lead.

7.2 Measuring output leads (output/powering circuit)

Connect the measuring output leads (analog output and power supply) to terminals \ominus and \oplus acc. to Fig. 7.

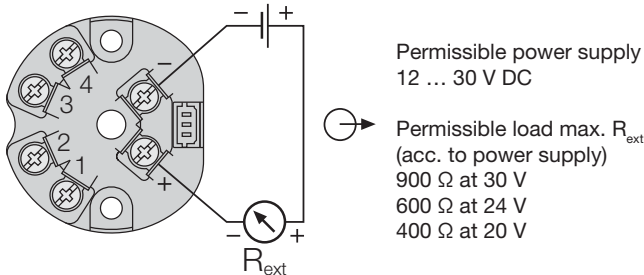

Fig. 7

Note, that twisted leads must be used for the output signal.

VK 616	Supply	Sensor: Pt100	CE	Camille Bauer AG Aargauerstr. 7 CH-5610 Wohlen Switzerland
Type 616-7111 4100 000	Voltage	Range: 0...100°C		
Ord: 616 / 123456 / 123 / 001	12...30V	Output: 4...20mA		

Fig. 8. Example of a nameplate.

8. Configuring the transmitter

The transmitter is configured via the serial interface of a PC. For the configuration, a special advantage is that devices of both the standard and Ex executions, with and without a separate power supply connection can be configured.

The following accessories are required:

... PC software V 600 plus

... Programming cable PK 610

... Ancillary cable for SINEAX Type VK 616

A PC with an RS 232 C interface (Windows 3.1x, 95, 98, NT or 2000) is also required.

The configuration procedure and choice of parameters is explained by the menu-guided configuration program.

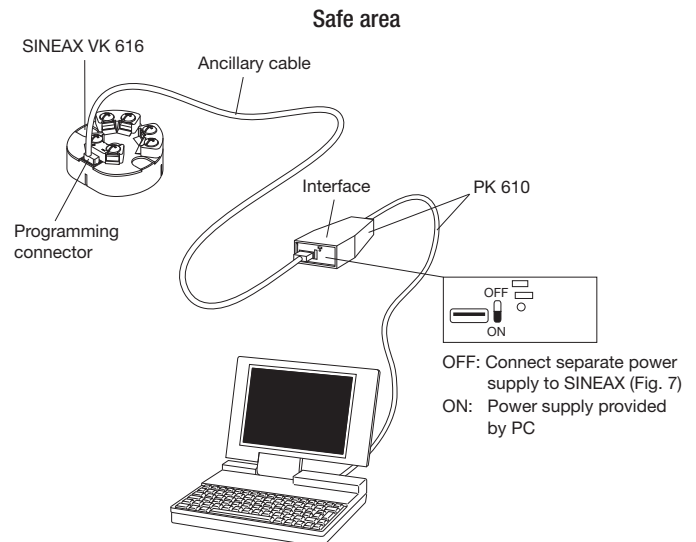

Fig. 9. Configuring of SINEAX VK 616 without the power supply. For this case the switch on the interface must be set to "ON".

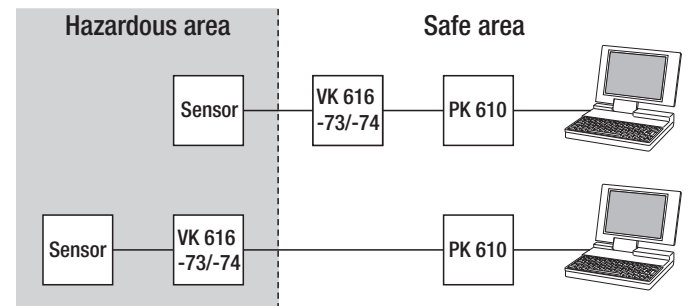

Fig. 10. Configuring the SINEAX VK 616, types 616-73/74 when the transducer and/or the sensor are in the hazardous are.

Depending on whether the device is programmed with or without a separate power supply, the switch on the PK 610 interface is to be set to "ON" or "OFF". See Fig. 9.



The earthing conditions must be observed when programming the instrument, (e.g. the instrument is installed in the plant).

If for the VK 616-72/-74 one of the input wires is earthed, or for the VK 616-71/-73 one of the power supply or input wires is earthed, a PC without an earth connection, must be used when programming (e.g. a notebook running on the batteries).

Under no circumstances should a PC be used running from a power supply with an earth connection, as this will damage the transducer.

 For devices of the explosion protection type “**intrinsically safe**”, the PC or laptop must support a voltage level of 500 Veff between the RS 232 interface and earth (e.g. battery operation). In particular, check other peripheral devices that are connected.

 If the above voltage level is not supported (e.g. operation from the mains power supply) the earth connection of the programming cable PK 610 must be connected to the potential equalization conductor. At the same time, it must be ensured that the programming circuit of the VK 616 is potential free.

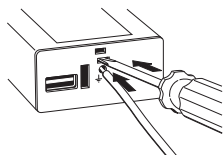

Fig. 11. Connect the earth connection to the PK 610 interface.

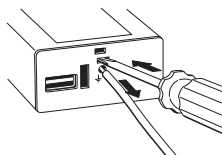

Fig. 12. Remove the earth connection from the PK 610 interface.

9. Commissioning



Switch on the measuring input and the power supply. The ambient temperature must be between - 10 and + 80 °C for standard instruments and - 10 and max. 57 °C for Ex versions (depending on P_r, see type examination certificate).

10. Maintenance

No maintenance is required.

11. Accessories and spare parts

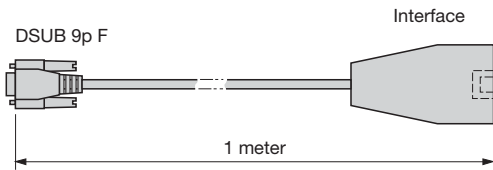
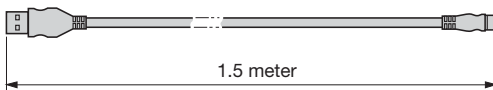
Description	Order No.
Programming cable PK 610 	137 887
Ancillary cable SINEAX type VK 616 	141 440
PC software V600 plus on CD (Download free of charge under http://www.camillebauer.com)	146 557
Operating Instructions VK 616 Bd in German	137 902
Operating Instructions VK 616 Bf in French	142 076
Operating Instructions VK 616 Be in English	142 125

12. Dimensional drawings

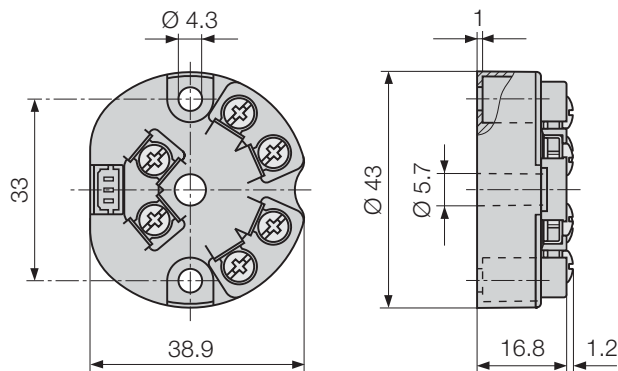

Fig. 13. SINEAX VK 616-71/73, **not** electrically isolated.

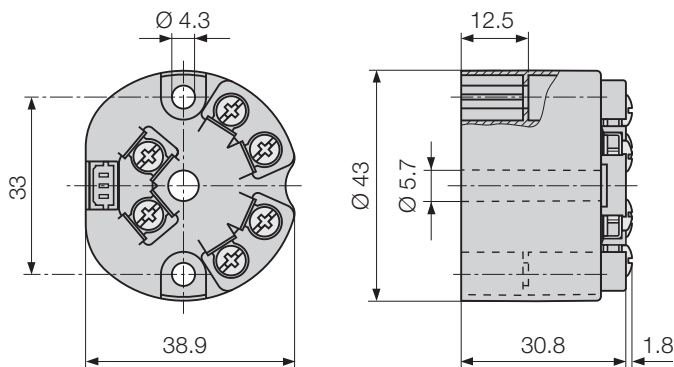





Fig. 14. SINEAX VK 616-72/74, **electrically** isolated.

13. Declaration of conformity

 EG - KONFORMITÄTSERKLÄRUNG  DECLARATION OF CONFORMITY	
Dokument-Nr./ Document No.:	VK616 GT.DOC
Hersteller/ Manufacturer:	Camille Bauer AG Switzerland
Anschrift / Address:	Aargauerstrasse 7 CH-5610 Wohlen
Produktbezeichnung/ Product name:	Programmierbarer Temperatur-Messumformer Programmable temperatur transmitter
Typ / Type:	SINEAX VK 616 GT
Das bezeichnete Produkt stimmt mit den Vorschriften folgender Europäischer Richtlinien überein, nachgewiesen durch die Einhaltung folgender Normen:	
The above mentioned product has been manufactured according to the regulations of the following European directives proven through compliance with the following standards:	
Nr. / No.	Richtlinie / Directive
2004/108/EG 2004/108/EC	Elektromagnetische Verträglichkeit - EMV - Richtlinie Electromagnetic compatibility - EMC directive
EMV / EMC	Fachgrundnorm / Generic Standard
Störaussendung / Emission	EN 61000-6-4 : 2007
Störfestigkeit / Immunity	EN 61000-6-2 : 2005
	Messverfahren / Measurement methods
	EN 55011 : 2007+A2:2007
	IEC 61000-4-2: 1995+A1:1998+A2:2001 IEC 61000-4-3: 2002+A1:2002 IEC 61000-4-4: 2004 IEC 61000-4-5: 2005 IEC 61000-4-6: 1996+A1:2001
Nr. / No.	Richtlinie / Directive
2006/95/EG 2006/95/EC	Elektrische Betriebsmittel zur Verwendung innerhalb bestimmter Spannungsgrenzen - Niederspannungsrichtlinie - CE-Kennzeichnung : 95 Electrical equipment for use within certain voltage limits - Low Voltage Directive - Attachment of CE mark : 95
EN/Norm/Standard	IEC/Norm/Standard
EN 61 010-1 : 2001	IEC 1010-1 : 2001
Die explosionsgeschützte Ausführung dieses Produkts stimmt mit der Europäischen Richtlinie 94/9/EG überein. The explosion protected variant of this product has been manufactured according to the European directive 94/9.	
Ort, Datum / Place, date:	Wohlen, 2.Oktobar.2008
Unterschrift / signature:	 
M. Ulrich Leiter Technik	J. Brem Qualitätsmanager